



audio-technica



# Wireless Systems 2025



# Wireless Systems

## WIRELESS INTRODUCTION

WIRELESS ATW-C.....	4
WIRELESS MANAGER - FREQUENCY.....	6
WIRELESS SERIES OVERVIEW.....	7

## WIRELESS SYSTEMS

5000 Series.....	8
Engineered Sound® Wireless.....	10
3000 Digital Series.....	14
3000 Series.....	16
3000 Series IEM.....	20
2000 Series.....	22
System 10 / System 10 PRO.....	24
System 20 PRO.....	28
AT-One.....	30
Antennas.....	32
Accessories.....	34
cH/cW Mic Summary.....	34-37

## WIRELESS APPLICATIONS

Application 1 - Dual-channel wireless system.....	38
Application 2 - Single-channel wireless system covering two zones.....	39
Application 3 - Multiple zones wireless system.....	40
Application 4 - Four-channel wireless system.....	42
Application 5 - Multi-channel wireless system for install.....	44
Application 6 - 16-channel wireless system using ATW-DA49a.....	46
Application 7 - 16-channel wireless system using daisy chain.....	48
Application 8 - 64-channel wireless system / 256-channel wireless system.....	50
Application 9 - ESW Application.....	52
Application 10 - Up to 192 Channels of ES Wireless.....	54
Radio Equipment Directive (RED) - Restrictions.....	56

/ Interchangeable  
Microphone  
Capsules (IMC)



/ Handheld  
Transmitter Body  
**ATW-T5202**



/ Cardioid  
Condenser  
**ATW-C5400**



/ Cardioid  
Condenser  
**ATW-C3300**



/ Hypercardioid  
Dynamic  
**ATW-C6100**



/ Cardioid  
Dynamic  
**ATW-C4100**



/ Cardioid  
Condenser  
**ATW-C710**



/ Cardioid  
Dynamic  
**ATW-C510**



/ Hypercardioid  
Dynamic  
**ATW-C990**



/ Handheld  
Transmitter Body  
**ATW-T3202**



/ Handheld  
Transmitter Body  
**ATW-DT3102**



/ Handheld  
Transmitter Body  
**ESW-T4102**



Interchangeable  
Microphone Capsules  
compatible with all  
Audio-Technica handheld  
transmitters with the  
interchangeable head  
option.

All interchangeable microphone capsules can be used with **ATW-T5202**, **ATW-T3202**, **ATW-DT3102** and **ESW-T4102** handheld transmitters. Its industry-standard thread allows use with other compatible handheld transmitters.

Condenser microphone capsules **ATW-C5400** and **ATW-C3300**.

An heritage from the world acclaimed studio microphones **AT4050** and **AT4033**.



/ Interchangeable Cardioid  
Condenser Microphone Capsule  
**ATW-C5400**

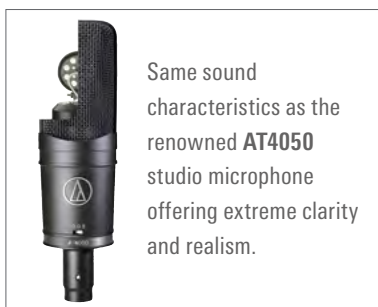

Same sound characteristics as the renowned **AT4050** studio microphone offering extreme clarity and realism.



/ Interchangeable Cardioid  
Condenser Microphone Capsule  
**ATW-C3300**



Same element as the classic **AT4033a** studio microphone offering extreme clarity and realism.

### Clean, Crisp and Accurate

Transparent uppers/mids and rich low-end qualities are combined with advanced acoustic engineering for extensive performance abilities and a clean, crisp and accurate sound reproduction, even at high SPLs.

### Warm and Flattering Sound

The AT4033a produces a warm and flattering sound that brings the versatility of a dynamic microphone, as well as the transparency and detail of a high-end capacitor model for a vintage effect.







/ Frequency-Agile True Diversity UHF  
**5000 Series**



/ DECT Wireless System (ESW)  
**Engineered Sound®  
Wireless**



/ Digital UHF Wireless Microphone System  
**3000 Digital Series**



/ Frequency-Agile True Diversity UHF  
**3000 Series**



/ Wireless In-Ear Monitor System  
**3000 Series IEM**



/ Frequency-Agile True Diversity UHF  
**2000 Series**



/ Digital Wireless System  
**System 20 Pro**



/ Rack-Mount Digital Wireless Systems  
**System 10 Pro**



/ Rack-Mount Digital Wireless Systems  
**System 10**



/ Antenna Switching Diversity UHF Wireless Systems  
**AT-One**

	Performance					Live Sound				Install			Broadcast & Production			
	Operating range	Indoor range	Outdoor range	Rec. Channel Count	Analog/Digital	Hobby music	Prof. music	Rental company	Theater	School / house of worship /	Corporate / hotel / conference room	Large venues / Stadium	Broadcast studio	ENG	Live sport	Film & Location sound
<b>5000 Series</b>	100 m	●●●●	●●●●	> 40	A	○	○○	○○	○○	○	○○	○○	○○		○○	○
<b>Engineered Sound Wireless</b>	100 m	●●●●	●	> 40	D					○○	○○	○○	○		○	
<b>3000 Digital Series</b>	120 m	●●●●	●●●●	> 40	D	○	○○	○○	○○	○○	○○	○○	○		○○	○
<b>3000 Series</b>	100 m	●●●●	●●●●	40	A	○○	○○	○○	○○	○○	○○	○○	○		○○	○
<b>3000 Series IEM</b>	90 m	●●●●	●●●●	> 40	A	○○	○○	○○	○○	○○	○	○○	○○	○○*	○○	○
<b>2000 Series</b>	100 m	●●●●	●●●●	30	A	○○	○	○○	○○	○○	○○	○				
<b>System 20 Pro</b>	60 m	●●●	●	20	D	○○	○○	○		○○	○○					
<b>System 10 Pro</b>	60 m	●●●	●	10	D	○○	○○	○		○○	○○					
<b>System 10</b>	30 m	●●	●	8	D	●●●	●●	●		○○	○			●●		●
<b>AT-One</b>	60 m	●●●	●●●	4	A	○○	○	○	○	○○	○○					

\* Should be combined with 3000 Series



# 5000 Series

Frequency-Agile True Diversity UHF Wireless Systems

## Comprehensive tuning bandwidth

For maximum versatility in ever-congested RF environment, the dual-channel receiver provides a tuning bandwidth of 230 MHz or 120 MHz (depending on frequency band). Both transmitters (ATW-T5202 and ATW-T5201) feature a tuning bandwidth of 120 MHz and are available in different frequency ranges to provide complete coverage of the receiver's bandwidth. This allows the user to set up systems with high channel counts, whilst offering the flexibility to tune to open spectrum wherever you travel.

## Dual compander for incredible audio quality

Designed for use on professional tours, in stadiums, concert halls, festivals and other demanding audio environments, the Audio-Technica 5000 Series offers the highest-quality wireless live sound, with dual-compander circuitry that processes high and low frequencies separately for unparalleled frequency response and dynamic range.

## Designed for professionals

The body-pack transmitter provides highest possible wearing comfort due to its small size - 64 mm × 70 mm × 17 mm, robust and ergonomic full metal body with concealed soft-touch controls, rugged cH-style connector for secure connection - just to name a few features that meet the needs of professional users.

## High channel count

The antenna cascade output connects up to 8 receivers, allowing a single pair of antennas to feed 16 channels of wireless.



Dante®

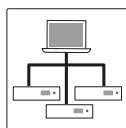

Network



Interchangeable Capsules

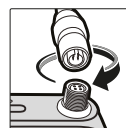

cH-Connector



back

/ Dante® Receiver  
**ATW-R5220DAN**



back

/ Receiver  
**ATW-R5220**



cH-style screw-down 4-pin connector for secure connection to A-T's cH-style lavalier and headworn microphones, or cables.

/ Body-Pack Transmitter  
**ATW-T5201**



/ Interchangeable  
Microphone Capsules (IMC)  
*(see page 4)*



/ Handheld Transmitter Body  
**ATW-T5202**

**5000 Series**

<b>Operating Frequencies</b>	Receiver: Band DG1: 470.125 to 699.875 MHz
	Band GH1: 700.125 to 819.875 MHz
	Transmitter: Band DE1: 470.125 to 590.000 MHz
	Band EG1: 580.000 to 699.875 MHz
	Band GH1: 700.125 to 819.875 MHz
<b>Minimum Frequency Step</b>	25 kHz
<b>Modulation Mode</b>	FM
<b>Operating Range</b>	100 m

**ATW-R5220/ATW-R5220DAN**

<b>Receiving System</b>	True diversity
<b>Image Rejection</b>	80 dB nominal
<b>Sensitivity</b>	18 dBuV at 60 dBA S/N ratio (50 ohms termination)
<b>Maximum Output Level</b>	XLR, balanced, +18 dBV
<b>Headphone Output</b>	6.3 mm (1/4") TRS stereo 180 mW, typical
<b>Antenna Input</b>	BNC-type, 50 ohms 12 V DC, 150 mA (combined)

**ATW-T5201**

<b>Frequency Response</b>	23 to 16,300 Hz
<b>Dynamic Range</b>	Mic input: 120 dB or higher (A-weighted), typical Inst input: 107 dB or higher (A-weighted), typical
<b>Input Connection</b>	cH-style screw-down 4-pin connector
<b>Spurious Emissions</b>	Following federal and national regulations
<b>Maximum Deviation</b>	±40 kHz (THD:10%)
<b>Total Harmonic Distortion</b>	1.0 % or less (at 1 kHz, ±17.5 kHz deviation)
<b>RF Power Output</b>	High: 50 mW, Mid: 10 mW, Low: 2 mW (switchable), at 50 ohms
<b>Battery Life</b>	High: 7 hours, Mid: 9 hours, Low: 10.5 hours (alkaline)
<b>Dimensions</b>	64 mm × 70 mm × 17 mm (W × D × H)
<b>Net Weight</b>	Approx. 92 g

**ATW-T5202**

<b>Frequency Response</b>	33 to 16,300 Hz Depending on attached microphone element
<b>Dynamic Range</b>	116 dB or higher (A-weighted), typical
<b>Microphone Element</b>	Interchangeable industry standard thread
<b>Spurious Emissions</b>	Following federal and national regulations
<b>Maximum Deviation</b>	±40 kHz (THD:10%)
<b>Total Harmonic Distortion</b>	1.0 % or less (at 1 kHz, ±17.5 kHz deviation)
<b>RF Power Output</b>	High: 50 mW, Mid: 10 mW, Low: 2 mW (switchable), at 50 ohms
<b>Battery Life</b>	High: 6.5 hours, Mid: 8 hours, Low: 9.5 hours (alkaline)
<b>Dimensions</b>	193 mm long, 37 mm maximum diameter
<b>Net Weight</b>	200 g



# Engineered Sound® Wireless

DECT Wireless System (ESW)

## High Channel Count

Select from standard mode (Up to 96 channels) to minimize latency, and HD mode (Up to 192 channels) to maximize the number of channels.

## Best-in-Class Battery Life

Internal batteries offer all-day operation on full charge, as well as rapid recharge ability in as little as 2 hours.

## Secure Communications

Stay confident that your communications will remain safe and secure with AES256 encryption support.



Dante®

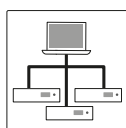

Network



Interchangeable Capsules

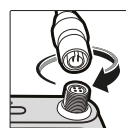

cH-Connector

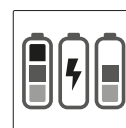

Charging contacts



front



back

The Engineered Sound Wireless System is available in two configurations:

/ 8ch Receiver  
**ESW-R4180DAN (Dante™)**  
**ESW-R4180LK (AT-Link)**



/ Body-Pack Transmitter  
**ESW-T4101**



/ Desk Stand Transmitter  
**ESW-T4107**



/ Boundary Microphone Transmitter  
**ESW-T4106**



/ Handheld Transmitter  
**ESW-T4102/C510**



/ for up to 8 transmitters with one power supply  
**Cascade recharging stations**

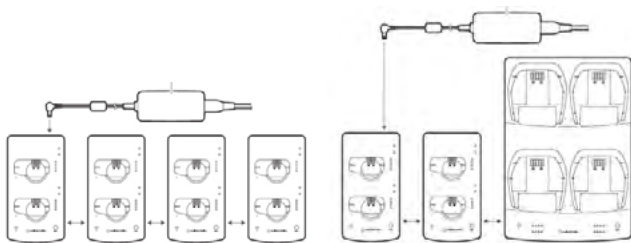

/ Two-Bay Charging Station  
**ESW-CHG4**



/ Four-Bay Charging Station  
**ESW-CHG5**



/ Power Supply Unit for ESW-CHG4  
 and ESW-CHG5  
**AD-SA1230XA**

ESW-R4180LK (only one unit connected)  
8 channel maximum per unit

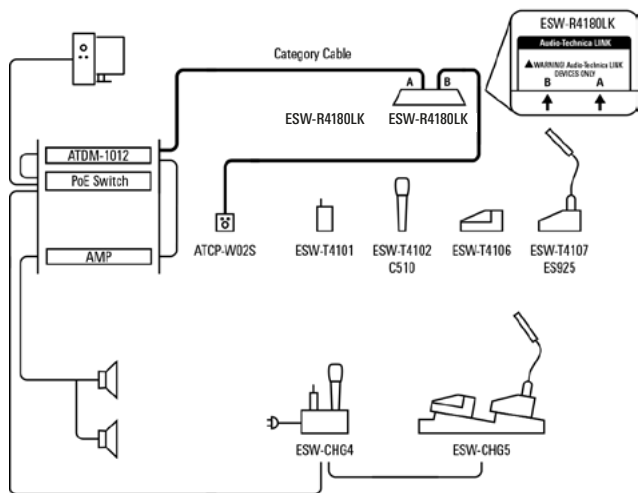

ESW-R4180LK (multiple units connected)  
16 channel maximum with 2 receivers

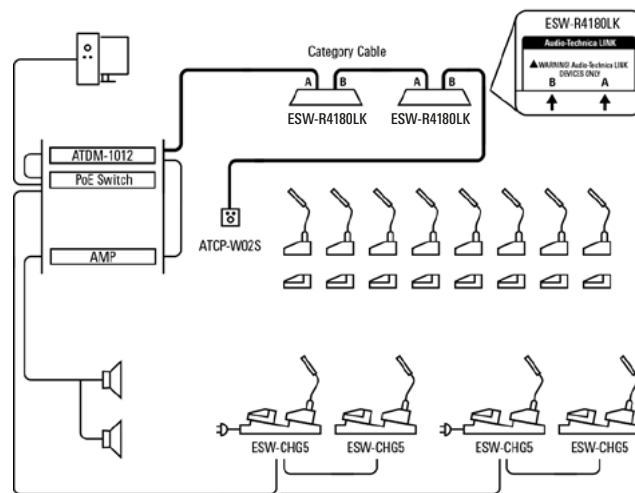

ESW-R4180DAN (only one unit connected)  
8 channel maximum per unit

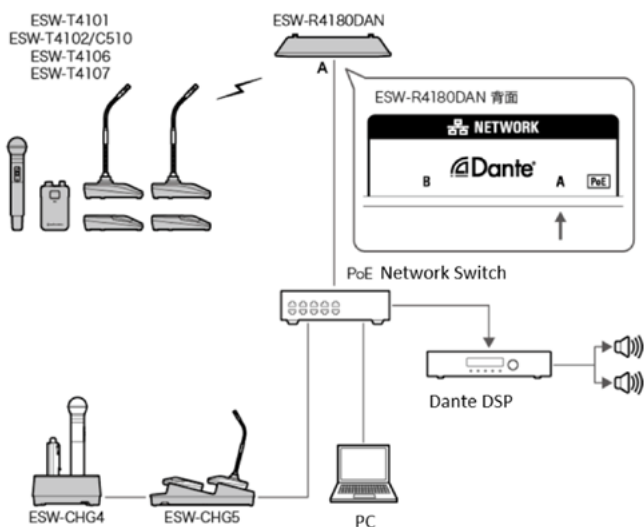

ESW-R4180DAN (multiple units connected)  
16 channel maximum with 2 receivers

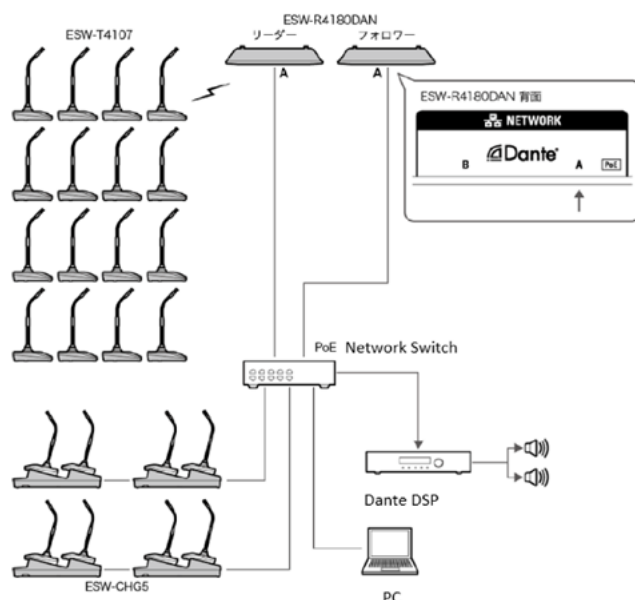

## Multi-hall complex / Exhibition centre

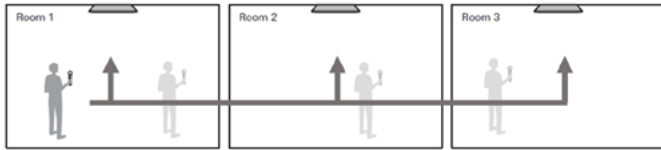

Roaming function allows transmitters to switch between multiple receivers (Dante™).

## Engineered Sound® Wireless

Operating Frequencies	1,880 to 1,900 MHz (Europe)
Operating Range	Max. 100 m (with RF Power set to Mid)
Dynamic Range	> 105 dB (A-weighted), typical
Total Harmonic Distortion	< 1.0%
Maximum Simultaneous Use (recommended)	Standard: 96 channels; HD mode: 192 channels
Receiving System	True diversity
Latency	Standard: 16.7 ms typ.; HD mode: 24.0 ms typ.
Audio Sampling Rate	24 bits, 48 kHz
Encryption System	AES256
RF Output Power	Max: 250mW, High: 100 mW, Mid: 30 mW, Low: 10 mW, Min: 2 mW (switchable)

## ESW-R4180DAN

Modulation Mode	A-field: $\pi$ / 2-BPSK; B-field: $\pi$ / 8-8PSK
RF Sensitivity	< -90 dBm
Network	Dante: 1 Gbps; IP Control: 100 Mbps
I/O Connector	Network/Dante: RJ-45
Power Consumption	4.8 W

## ESW-T4101

Frequency Response (internal microphone)	20 to 20,000 Hz
Modulation Mode	A-field: $\pi$ / 2-BPSK; B-field: $\pi$ / 4-QPSK
Input Connection	Four pin screw-down cH-connector
Battery	Lithium-ion battery LI-220 (included)
Battery Life	25 hours
Dimensions	56 mm x 23.5 mm x 90 mm (W x D x H)
Weight (with battery)	112.3 g

## ESW-T4102

Modulation Mode	60 to 16,000 Hz
Microphone Capsule	108 dB or higher (A-weighted), typical
Battery	Cardioid, condenser
Battery Life	Following federal and national regulations
Dimensions	$\pm 40$ kHz (THD:10%)
Weight (with battery)	1.0 % or less (at 1 kHz, -20 kHz deviation)

## ESW-T4106

Frequency Response	Omnidirectional: 20 to 18,000 Hz; Cardioid: 20 to 18,000 Hz
Modulation Mode	A-field: $\pi$ / 2-BPSK; B-field: $\pi$ / 4-QPSK
Microphone Polar Pattern	Cardioid, Omnidirectional (selectable)
Battery	Lithium-ion battery LI-220 (included)
Battery Life	22 hours
Charging Time (USB)	Approx. 2 hours 40 minutes
USB Charging Connector	USB Type-C (USB 3.0)
Dimensions	90.5 mm x 129.4 mm x 31.9 mm (W x D x H)
Weight (with battery)	500 g

## ESW-T4107

Modulation Mode	A-field: $\pi$ / 2-BPSK; B-field: $\pi$ / 4-QPSK
Microphone	ES Series modular gooseneck microphone-compatible
Battery	Lithium-ion battery LI-220 (included)
Battery Life	17 hours
Charging Time (USB)	Approx. 2 hours 40 minutes
USB Charging Connector	USB Type-C (USB 3.0)
Dimensions	90.5 mm x 129.4 mm x 47.4 mm (W x D x H)
Weight (with battery)	535 g

## ESW-R4180LK

Modulation mode	A-field: $\pi$ /2-BPSK B-field: $\pi$ /8-8PSK
RF sensitivity	< -90 dBm
Network interface	Audio-Technica LINK: 100 Mbps
I/O connector	Audio-Technica LINK: RJ-45
Power consumption	2.4 W
Power requirement	+48 V DC (Audio-Technica LINK)
Operating temperature range	-10°C to +50°C
Dimensions	228.6 mm x 228.6 mm x 43.5 mm (WxDxH)
Weight (without accessories)	620 g
Included accessories	Mounting bracket

## ESW-CG5

Power Supply	12 V DC, 3 A
Charging Output	Charging 1 to 4 transmitters: 4.2 V DC, 1.5 A Charging 5 to 6 transmitters: 4.2 V DC, 1.1 A Charging 7 to 8 transmitters: 4.2 V DC, 0.7 A
Consumption	Charging 4 transmitters: 30.6 W
Charging Time (ESW-T4106 / ESW-T4107)	1 to 4 transmitters: 100%-2h00 / 50%-0h50 5 to 6 transmitters: 100%-2h50 / 50%-1h10 7 to 8 transmitters: 100%-3h40 / 50%-1h40
Network Interface	IP: 100 Mbps
Operating Temperatures	0°C to 40°C
Dimensions	209.9 x 303.9 x 65.4 mm (L x W x H)
Weight	866 g
Included Accessories	Link cable, link plate, plate screws
Sold Separately	AC Adapter (AD-SA1230XA), AC cord

## ESW-CHG4

Power Supply	12 V DC, 3 A
Charging Output	Charging 1 to 4 transmitters: 4.2 V DC, 1.5 A Charging 5 to 6 transmitters: 4.2 V DC, 1.1 A Charging 7 to 8 transmitters: 4.2 V DC, 0.7 A
Consumption	Charging 2 transmitters: 15.6 W 4 chained stations/8 transmitters: 30.6 W
Charging Time (ESW-T4101)	1 to 4 transmitters: 100%-2h00 / 50%-0h50 5 to 6 transmitters: 100%-2h50 / 50%-1h10 7 to 8 transmitters: 100%-3h40 / 50%-1h40
Charging Time (ESW-T4102)	1 to 4 transmitters: 100%-3h00 / 50%-1h20 5 to 6 transmitters: 100%-4h10 / 50%-1h40 7 to 8 transmitters: 100%-5h20 / 50%-2h20
Network Interface	IP: 100 Mbps
Operating Temperatures	0°C to 40°C
Dimensions	95 x 180 x 78.5 mm (L x W x H)
Weight	532 g
Included Accessories	Link cable, link plate, plate screws, microphone suspension adapter
Sold Separately	AC/DC Adapter (AD-SA1230XA), power cord

(1) Depending on environmental conditions.



# 3000 Digital Series

Digital UHF Wireless Microphone System

## Uncompromising high-quality sound

In addition to 24-bit / 48 kHz digital processing, the 3000 Digital Series features a wide 120 dB dynamic range. Our proprietary audio codec technology accurately represents high frequencies, making the system well suited for use with musical instruments, as well as voices.

## 60 MHz tuning range

Features an extremely wide 60 MHz UHF tuning bandwidth for maximum versatility in an increasingly congested RF environment.

## Dante™ output

The ATW-DR3120DAN features Dante™, providing a low-latency, high-performance network audio solution which is easy to implement, use and extend.

## Cost & Space Saving

Up to five receivers can be cascaded together meaning no antenna distributor is required. Without the need for antenna distributors, the entire rack space can be slimmed down, reducing upstart, operating and travel costs.



Dante®

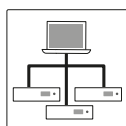

Network



Interchangeable Capsules

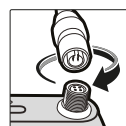

cH-Connector

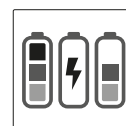

Charging contacts



front



back

/ Dual-Channel Receiver  
**ATW-DR3120DAN**



ch-style screw-down 4-pin connector for secure connection to A-T's ch-style lavalier and headworn microphones, or cables.

/ Body-Pack Transmitter  
**ATW-DT3101**



/ Interchangeable  
Microphone Capsules (IMC)  
(see page 4)



/ Handheld Transmitter Body  
**ATW-DT3102**

**3000 Digital Series**

<b>Operating Frequencies</b>	Band DE2E: 470.125 to 529.975 MHz Band EE1E: 530.000 to 589.975 MHz Band FF1E: 606.000 to 665.975 MHz
<b>Minimum Frequency Step</b>	25 kHz
<b>Modulation Mode</b>	e microphone element used
<b>Operating Range</b>	120 m
<b>Total Harmonic Distortion</b>	0.1% or less (at 1 kHz, -20 dBFS)

**ATW-DR3120DAN Dual-Channel Receiver**

<b>Receiving System</b>	True diversity
<b>Image Rejection</b>	70 dB
<b>RF Sensitivity</b>	-98 dBm (10-5 BER)
<b>Maximum Output Level</b>	18 dBV (Line), -12 dBV (Mic)
<b>Antenna Input</b>	BNC-type, 50 ohms
<b>Antenna Power</b>	12 VDC, 150 mA (combined)
<b>Power Supply</b>	100 to 240 VAC (50/60 Hz)
<b>Dimensions</b>	483 mm × 385 mm × 44 mm (W × D × H)
<b>Weight</b>	Approx. 4.1 kg

**ATW-DT3101 Body-Pack Transmitter**

<b>RF Power Output</b>	High: 20 mW, Mid: 10 mW, Low: 2 mW
<b>Dynamic Range</b>	Mic input: 120 dB or higher, A-weighted, typical Inst input: 108 dB or higher, A-weighted, typical
<b>Battery Type</b>	Two alkaline or nickel-metal hydride 1.5 V AA batteries
<b>Battery Life</b>	Nickel-metal hydride 1.5 V AA batteries: Approx. 7 hours (1900 mAh High), Approx. 9 hours (2500 mAh High); Alkaline 1.5 V AA batteries: Approx. 6 hours (High)
<b>Dimensions</b>	64 mm × 23 mm × 82 mm (W × D × H)
<b>Input Connections</b>	Four pin locking connector
<b>Weight</b>	Approx. 105 g

**ATW-DT3102 Handheld Transmitter Body**

<b>RF Power Output</b>	High: 20 mW, Mid: 10 mW, Low: 2 mW
<b>Dynamic Range</b>	120 dB or higher, A-weighted, typical
<b>Battery Type</b>	Two alkaline or nickel-metal hydride 1.5 V AA batteries
<b>Battery Life</b>	Nickel-metal hydride 1.5 V AA batteries: Approx. 7 hours (1900 mAh High), approx. 9 hours (2500 mAh High); Alkaline 1.5 V AA batteries: Approx. 6 hours (High)
<b>Dimensions</b>	193 mm × 37 mm (without microphone capsule)
<b>Weight</b>	Approx. 205 g



## 3000 Series

Frequency-Agile True Diversity UHF Wireless Systems

### 60 MHz tuning bandwidth

The 3000 Series systems are available in several different frequency bands, and each features a wide 60 MHz tuning range. This allows the user to set up systems with high channel counts, whilst offering the flexibility to tune to open spectrum wherever you travel. Frequencies can be easily scanned and selected on the receiver and then synced with the transmitter via IR sync functionality.

### Backup frequency button

Unique multifunction button on the handheld and body-pack transmitters can be used to switch to a backup frequency (on both transmitter and receiver) should interference be encountered.

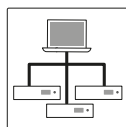

Network

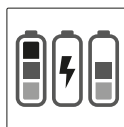

Charging contacts



Interchangeable Capsules

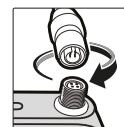

cH-Connector



front



back

/ Receiver  
**ATW-R3210**



back

/ Network-Enabled Receiver  
**ATW-R3210N**



/ Body-Pack Transmitter  
**ATW-T3201**

cH-style screw-down 4-pin connector for secure connection to A-T's cH-style lavalier and headworn microphones, or cables.



/ Interchangeable  
Microphone Capsules (IMC)  
*(see page 4)*



/ Handheld Transmitter Body  
**ATW-T3202**





## One power supply feeds up to five chargers

Up to five docks can be connected to one power supply (AD-SA1230XA - available separately) to charge a maximum of ten transmitters (per link one AT8687 is required - available separately).

## Monitoring and controlling

The ATW-CHG3N networked version of the charging dock allows users to monitor the charging status of all transmitters in the linked docks (per link one AT8687 is required - available separately). Only the first dock must be an ATW-CHG3N, all linked docks (up to four) must be ATW-CHG3.

## Protection against misuse

The dock automatically shuts off if alkaline or damaged batteries are detected in the transmitters.



/ Two-Bay Charging Station  
**ATW-CHG3a**

/ Two-Bay Networked Charging Station  
**ATW-CHG3Na**

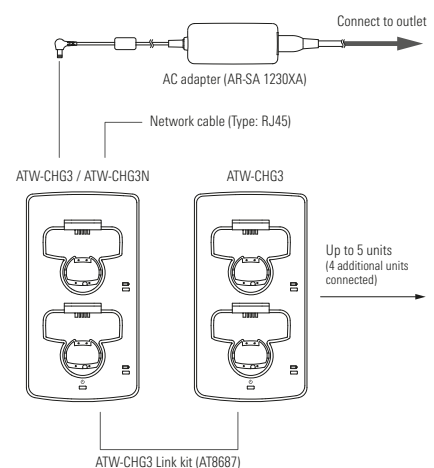



/ Power Supply Unit for ATW-CHG3  
**AD-SA1230XA**



/ Link Kit for ATW-CHG3  
**AT8687**

**ATW-CHG3 Charging Station**

<b>Charging Time</b>	Approx. 6.5 hours (1,900 mAh rechargeable battery)
<b>Power Supply</b>	DC12V 3.0A
<b>Power Consumption</b>	4.9W (when 2 transmitters are charging) 27.4W (CHG3x5) (5 units are connected and 10 transmitters are charging)
<b>Weight</b>	400 g
<b>Accessories</b>	Separately available - AC adapter (AD-SA1230XA), ATW-CHG3 Link kit (AT8687)

**3000 Series**

<b>Operating Frequencies</b>	Band DE2: 470.125 to 529.975 MHz Band EE1: 530.000 to 589.975 MHz Band EF1: 590.000 to 649.975 MHz Band FG1: 650.000 to 699.875 MHz Band HH3: 821.100 to 831.900 MHz and 863.100 to 864.900 MHz
<b>Minimum Frequency Step</b>	25 kHz
<b>Modulation Mode</b>	FM
<b>Operating Range</b>	100 m

**ATW-R3210/ATW-R3210N**

<b>Receiving System</b>	True diversity
<b>Image Rejection</b>	60 dB nominal
<b>Sensitivity</b>	20 dB $\mu$ V at 60 dBA S/N ratio (50 ohms termination)
<b>Maximum Output Level</b>	XLR, balanced, +14 dBV 6.3 mm (1/4"), unbalanced: +8 dBV (ATW-R3210 only)
<b>Antenna Input</b>	BNC-type, 50 ohms 12 V DC, 160 mA (combined)

**ATW-T3201**

<b>Frequency Response</b>	31 to 15,500 Hz
<b>Dynamic Range</b>	Mic input: 115 dB or higher (A-weighted), typical Inst input: 112 dB or higher (A-weighted), typical
<b>Input Connection</b>	cH-style screw-down 4-pin connector
<b>Spurious Emissions</b>	Following federal and national regulations
<b>Maximum Deviation</b>	$\pm$ 38 kHz (THD:10%)
<b>Total Harmonic Distortion</b>	1.0 % or less (at 1 kHz, $\pm$ 17.5 kHz deviation)
<b>RF Power Output</b>	High: 30 mW, Low: 10 mW (switchable), at 50 ohms
<b>Battery Life</b>	High: 8 hours, Low: 9 hours (alkaline) High: 9 hours, Low: 9.5 hours (Ni-MH 1900mAh)
<b>Dimensions</b>	64 mm x 82 mm x 23 mm (W x D x H)
<b>Net Weight</b>	Approx. 102 g

**ATW-T3202**

<b>Frequency Response</b>	25 to 16,700 Hz (Depending on attached microphone element)
<b>Dynamic Range</b>	115 dB or higher (A-weighted), typical
<b>Microphone Element</b>	Interchangeable industry standard thread
<b>Spurious Emissions</b>	Following federal and national regulations
<b>Maximum Deviation</b>	$\pm$ 36 kHz (THD:10%)
<b>Total Harmonic Distortion</b>	1.0 % or less (at 1 kHz, $\pm$ 17.5 kHz deviation)
<b>RF Power Output</b>	High: 30 mW, Low: 10 mW (switchable), at 50 ohms
<b>Battery Life</b>	High: 8 hours, Low: 9 hours (alkaline) High: 9 hours, Low: 9.5 hours (Ni-MH 1900mAh)
<b>Dimensions</b>	193 mm long, 37 mm maximum diameter
<b>Net Weight</b>	200 g



/ 3000 Series -  
Body-pack System  
**ATW-3211**



/ 3000 Series -  
Handheld System with ATW-C510  
**ATW-3212/C510<sup>o</sup>**



/ 3000 Series -  
Handheld System with ATW-C710  
**ATW-3212/C710**



## 3000 Series IEM

3000 Series Wireless In-Ear Monitor System

### 138MHz tuning bandwidth

The 3000 Series IEM systems are available in two different frequency bands, and each features a wide 138 MHz tuning range. This allows the user to set up systems with high channel counts, whilst offering the flexibility to tune to open spectrum wherever you travel.

### Pro in-ear monitors are part of the package

The 3000 Series Wireless IEM comes with the ATH-E40 in-ear monitor headphones for professional performance right out of the box.

### Stay in control

Audio-Technica's Wireless Manager software provides a powerful, easy-to-use network tool for setting up, controlling and monitoring the IEM system. Frequencies can be easily scanned on the receiver and then synced with the transmitter via IR sync functionality to create frequency plans..

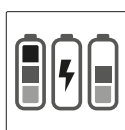

Charging contacts



cW-Connector

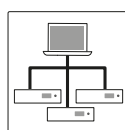

Network



front



back

/ Stereo Transmitter  
**ATW-T3205**



cH-style screw-down  
4-pin connector for secure  
connection

/ Stereo Receiver  
**ATW-R3250**



/ Dynamic In-Ear Headphones  
**ATH-E40**



/ Two-Bay Charging Station  
**ATW-CHG3a**

/ Two-Bay Networked Charging Station  
**ATW-CHG3Na**

**3000 Series IEM**

<b>Operating Frequencies</b>	DF2: 470.125 to 607.875 MHz; EG2: 580.000 to 713.850 MHz
<b>Minimum Frequency Step</b>	25 kHz
<b>Modulation Mode</b>	FM
<b>Nominal/Peak Deviation</b>	±34 kHz nominal / ±45 kHz peak
<b>Frequency Response</b>	40 Hz to 14,100 Hz
<b>Stereo Separation</b>	75 dB
<b>Operating Range</b>	90 m
<b>Dynamic Range</b>	>90 dB, A-weighted, typical
<b>Total Harmonic Distortion</b>	<0.2% (at 1 kHz, +4dBu input)

**ATW-T3205**

<b>RF Output Power</b>	High: 50 mW, Low: 10 mW (switchable) at 50 ohms
<b>Input Connection</b>	XLR-F type×2
<b>Maximum Input Level</b>	XLR-F type: +24 dBu (at 0 dB sensitivity)
<b>Output Connection</b>	6.3 mm (1/4") TRS×2
<b>Network</b>	100BASE-T
<b>Network Port</b>	RJ-45
<b>Power Supply</b>	100 to 240 V AC (50/60 Hz) to 12V DC 1 A (center positive) switched mode external power supply
<b>Antenna Output</b>	BNC-type, 50 ohms
<b>Dimensions</b>	210 mm ×191 mm ×43.4 mm (W×D×H)
<b>Weight</b>	1,100 g

**ATW-R3250**

<b>Receiving System</b>	Antenna diversity <i>Audio output cable performs as a secondary antenna to ensure stable RF performance.</i>
<b>Image Rejection</b>	>80 dB, typical
<b>RF Sensitivity</b>	20 dBuV at 60 dBA S/N ratio (50 ohms termination)
<b>Headphone Output Jack</b>	3.5 mm (1/8") TRS stereo mini-jack
<b>Headphone Output</b>	40 mW (at 12 ohms)
<b>Antenna Input</b>	SMA type, 50 ohms
<b>Dimensions</b>	64 mm ×23 mm ×82 mm (W×D×H)
<b>Weight</b>	102 g (without batteries)
<b>Battery Current/Life</b>	4 to 6 hours (alkaline); 5 to 7 hours (Ni-MH, 1900 mAh); 11 to 13 hours (Lithium)
<b>Battery Type</b>	3 V DC (two 1.5 V AA) (not included)



## 2000 Series

Frequency-Agile True Diversity UHF Wireless Systems

### Easy to use

Easy setup, automatic scanning and other advanced wireless features - affordable as never before. Though the 2000b system is designed for professional use, the user does not need special training to operate it. Once unboxed, it's ready to roll! Standard automatic frequency scanning finds and sets the best available channel at the touch of a button. Using multiple wireless systems simultaneously, as any of its 10 preset channels can be used together.

### 12V antenna power

The ATW-R2100c receiver delivers a bias voltage of 12V / 60mA from each BNC antenna input, enabling the use of antenna boosters or other active components.

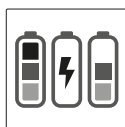

Charging contacts



cW-Connector



front



back

/ Receiver  
**ATW-R2100c**

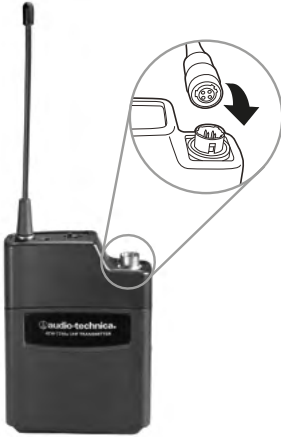

Locking 4-pin microphone connector for use with Audio-Technica cW-style wireless body-pack transmitters.

/ Body-pack Transmitter  
**ATW-T210c**



/ Handheld Transmitter  
**ATW-T220c**



/ Two-Bay Recharging Station  
**ATW-CHG2**

**2000 Series**

<b>Operating Frequencies</b>	I Band: 487.125 to 506.500 MHz U Band: 606.500 to 631.000 MHz D Band: 656.125 to 678.500 MHz F Band: 854.900 to 864.900 MHz
<b>Max. Number of Channels</b>	10
<b>Modulation Mode</b>	FM
<b>Operating Range</b>	100 m

**ATW-R2100c**

<b>Receiving System</b>	True diversity
<b>Image Rejection</b>	55 dB nominal, 50 dB minimum
<b>Sensitivity</b>	20dB $\mu$ V (S/N 60dB at 5 kHz deviation, IEC-weighted)
<b>Maximum Output Level</b>	XLR, balanced, +14 dBV - 6.3 mm (1/4), unbalanced: +8 dBV
<b>Antenna Input</b>	BNC-type, 50 ohms 12 V DC, 60 mA (each)

**ATW-T210c**

<b>Frequency Response</b>	100 to 15,500 Hz
<b>Dynamic Range</b>	110 dB or higher (A-weighted), typical
<b>Input Connection</b>	cW-style lock-down 4-pin connector
<b>Spurious Emissions</b>	Following federal and national regulations
<b>Maximum Deviation</b>	$\pm$ 40 kHz (THD:10%)
<b>Total Harmonic Distortion</b>	1.0 % or less (at 1 kHz, $\pm$ 17.5 kHz deviation)
<b>RF Power Output</b>	High: 30 mW, Low: 10 mW (switchable)
<b>Battery Life</b>	High: 7 hours, Low: 9 hours (alkaline)
<b>Dimensions</b>	66 mm $\times$ 92 mm $\times$ 23 mm (W $\times$ D $\times$ H)
<b>Net Weight</b>	Approx. 81 g

**ATW-T220c**

<b>Frequency Response</b>	100 to 15,000 Hz
<b>Dynamic Range</b>	110 dB or higher (A-weighted), typical
<b>Microphone Element</b>	Cardioid, dynamic
<b>Spurious Emissions</b>	Following federal and national regulations
<b>Maximum Deviation</b>	$\pm$ 40 kHz (THD:10%)
<b>Total Harmonic Distortion</b>	1.0 % or less (at 1 kHz, $\pm$ 20 kHz deviation)
<b>RF Power Output</b>	High: 30 mW, Low: 10 mW (switchable)
<b>Battery Life</b>	High: 7 hours, Low: 9 hours (alkaline)
<b>Dimensions</b>	232 mm long, 48 mm maximum diameter
<b>Net Weight</b>	252 g



/ 2000 Series - Body-pack System  
**ATW-2110c**



/ 2000 Series - Handheld System  
**ATW-2120b**

# System 10

Digital Wireless Systems

## Easy to use

System 10 is a digital high-fidelity wireless system designed to provide 24-bit operation, easy setup and clear, natural sound quality. Operating in the 2.4 GHz range, far from TV and DTV interference, System 10 offers extremely easy operation and instantaneous channel selection. Up to eight channels may be used together without any frequency coordination problems or group selection issues. System 10 receivers and transmitters offer an easy-to-read digital ID display.

## Three levels of diversity assurance

System 10 provides three levels of diversity: frequency, time and space. Frequency diversity transmits the signal on two frequencies simultaneously for better protection against frequency interference. Time diversity sends the signal twice to maximise signal integrity. Finally, space diversity uses two antennas on each transmitter and receiver to optimize immunity against multipath interference.



Frequency



cW-Connector



# System 10 PRO

Digital Wireless Systems

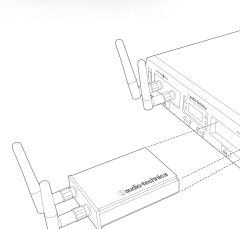

**Featuring**  
Remote-Mountable  
Receiver Units

## A compact and expandable system

With an RJ12 cable supplied with each system, it is possible to connect up to 5 frames (10 receivers). While many systems can operate without being connected, this is not recommended. Indeed, linking the systems to create a more stable environment in which receivers are coordinated for the reception, transmission and frequency allocation avoids signal loss and optimizes the simultaneous use of the 10 channels.



/ Single Channel Receiver  
**ATW-R1310**

front



/ Dual Channel Receiver  
**ATW-R1320**

front



Locking 4-pin microphone connector for use with Audio-Technica cW-style wireless body-pack transmitters.



/ Body-Pack Transmitter  
**ATW-T1001**  
(specifications, see page 20)



back

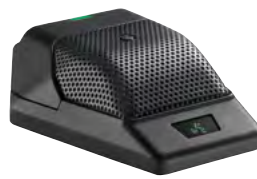

/ Boundary Microphone Transmitter  
**ATW-T1006**



/ Microphone Desk Stand Transmitter  
**ATW-T1007**



/ Handheld Transmitter-  
**ATW-T1002**  
(specifications, see page 20)



/ System 10 PRO -  
Rack-Mount Digital Wireless System  
**ATW-1301**



/ System 10 PRO -  
Rack-Mount Digital Wireless System  
**ATW-1311**



/ System 10 PRO -  
Rack-Mount Digital Wireless System  
**ATW-1312**



/ System 10 PRO -  
Rack-Mount Digital Wireless System  
**ATW-1302**



/ System 10 PRO -  
Rack-Mount Digital Wireless System  
**ATW-1322**

**System 10 PRO**

Operating Frequencies	2.4 GHz ISM Band
Max. Number of Channels	10
Audio Sampling	24 bit / 48 kHz
Operating Range	60 m

**ATW-R1310 & ATW-R1320**

Receiving System	Diversity (frequency / time / space)
Maximum Output Level	XLR, balanced, +6 dBV - 6.3 mm (1/4), unbalanced: 0 dBV

**ATW-T1006**

Maximum Input Sound Level	139 dB SPL
RF Power Output	10 mW
Spurious Emissions	Following federal and national regulations
Internal Battery	3.7 V Rechargeable Li-ion Battery
Battery Rating	5.5 Wh; 1,460 mAh
Battery Life	9 hours (Battery charging time: 4 hours 30 minutes)
Dimensions	96.1 mm W × 38.0 mm H × 122.8 mm D
Net Weight	408 grams

**ATW-T1007**

RF Power Output	10 mW
Spurious Emissions	Following federal and national regulations
Phantom Power	12V DC
Internal Battery	3.7 V Rechargeable Li-ion Battery
Battery Rating	5.5 Wh; 1,460 mAh
Battery Life	9 hours (Battery charging time: 4 hours 30 minutes)
Dimensions	96.1 mm W × 44.2 mm H × 122.8 mm D
Net Weight	392 grams



# System 10

Digital Wireless Systems

## Automatic frequency selection

The System 10 automatically changes its frequency. Unlike other systems on the market that attach to 2 or 4 frequency, the System 10 will constantly “monitor” the frequencies and switch if necessary. Thus, there are always a good 2 frequencies in the system, and the user does not need to manually intervene.



/ Receiver  
**ATW-R1100**



Locking 4-pin microphone connector for use with Audio-Technica cW-style wireless body-pack transmitters.

/ Body-Pack Transmitter  
**ATW-T1001**



Handheld Transmitter /  
**ATW-T1002**



/ System 10 -  
Body-pack System  
**ATW-1101**



/ System 10 -  
Handheld System  
**ATW-1102**

### System 10 - Stack-Mount

Operating Frequencies	2.4 GHz ISM Band
Max. Number of Channels	8
Audio Sampling	24 bit / 48 kHz
Operating Range	30 m

### ATW-R1100

Receiving System	Diversity (frequency / time / space)
Maximum Output Level	XLR, balanced, +6 dBV - 6.3 mm (1/4), unbalanced: 0 dBV

### ATW-T1001

Frequency Response	20 to 20,000 Hz
Dynamic Range	109 dB or higher (A-weighted), typical
Input Connection	cW-style lock-down 4-pin connector
Spurious Emissions	Following federal and national regulations
Total Harmonic Distortion	0.05 % or less
RF Power Output	10 mW
Battery Life	7 hours (alkaline)
Dimensions	72 mm × 107 mm × 25 mm (W × D × H)
Net Weight	Approx. 100 g

### ATW-T1002

Frequency Response	20 to 20,000 Hz
Dynamic Range	109 dB or higher (A-weighted), typical
Microphone Element	Unidirectional, dynamic
Spurious Emissions	Following federal and national regulations
Total Harmonic Distortion	0.05 % or less
RF Power Output	10 mW
Battery Life	7 hours (alkaline)
Dimensions	255 mm long, 50 mm maximum diameter
Net Weight	280 g



# System 10 Camera-Mount

Portable Camera-Mount Digital Wireless Systems

## Small and compact design

With its compact and portable design, the System 10 Digital Wireless Camera System is ideal for video production, reporting and all intermediate mobile applications, the receiver offers several mounting options to suit a wide variety of cameras and recording devices. Each System 10 camera mount wireless system includes a camera mounting spigot in addition to the receiver and the transmitter.

/ Camera-Mount Receiver  
**ATW-R1700**



/ Body-Pack Transmitter  
**ATW-T1001** (see page 20)

/ Handheld Transmitter  
**ATW-T1002** (see page 20)



System 10 -  
Camera-mount Body-pack System  
**ATW-1701**



/ System 10 -  
Camera-mount Handheld System  
**ATW-1702**

### System 10 - Camera-Mount

<b>Operating Frequencies</b>	2.4 GHz ISM Band
<b>Max. Number of Channels</b>	8
<b>Audio Sampling</b>	24 bit / 48 kHz
<b>Operating Range</b>	30 m

### ATW-R1700

<b>Receiving System</b>	Diversity (frequency / time / space)
<b>Maximum Output Level</b>	3.5 mm, TRS balanced, +6 dBV 3.5 mm, TRS unbalanced: 0 dBV
<b>Battery Type</b>	Internal Battery: 3.7V rechargeable Li-ion battery
<b>Battery Life</b>	12 hours (Battery charging time: 4 hours 30 minutes)
<b>Dimensions</b>	56 mm × 91 mm × 28 mm (W × D × H)
<b>Weight</b>	Approx 105 g

# System 20 PRO

Digital Wireless System

**2.4 GHz**  
Frequency

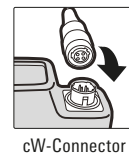

## A New Level of Functionality and Convenience

When we launched the System 10 PRO rack-mount receiver we took 2.4 GHz wireless microphone systems to a new level of functionality and convenience. Now, with the System 20 PRO we take it even further, offering a self-managing, plug-and-play 2.4 GHz system that's scalable to 20 channels and delivers the same dependable, high-quality audio – regardless of where you set it up. Designed for hassle-free deployment, the system overcomes many challenges of conventional wireless microphones, such as frequency coordination, complex intermodulation calculations, and remote antenna cabling.

## Easy Installation

Capable of receiving up to four transmitters, the system's ATW-R1440 receiver makes installation a breeze. Receiver units can remain docked in the half-rack chassis or be mounted remotely (up to 328 feet away) via Ethernet cable for added versatility. Up to five chassis can be linked using the included RJ12 cable, creating a stable, multichannel system with the simultaneous use of up to 20 channels. But the user is always free to choose the most effective operation mode for a given situation: Standard mode (10 channels) to minimise latency or HD mode (20 channels) to maximise channel count.

/ 4-Channel Receiver  
**ATW-R1440**



/ Body-Pack Transmitter  
**ATW-T1401**

Locking 4-pin microphone connector for use with Audio-Technica cW-style wireless body-pack transmitters.



/ Handheld Microphone Transmitter  
**ATW-T1402**



/ Boundary Microphone Transmitter  
**ATW-T1406**

/ Two-Bay Networked Charging Station  
**ATW-CHG3Na**

/ Two-Bay Charging Station  
**ATW-CHG3a**



/ Desk Stand Transmitter  
**ATW-T1407**



**Overall System Specifications**

<b>Operating frequencies</b>	2402 - 2480MHz
<b>Dynamic range</b>	120dB (A-weighted) typical
<b>Total harmonic distortion</b>	< 0.05% typical
<b>Operating range</b>	60m (Open environment with no interfering signals)
<b>System Frequency Response</b>	20 to 20000Hz (Varies depending on the microphone to be installed)
<b>Delay</b>	Standard: 2.8ms, HD mode: 6.7ms
<b>Audio sampling frequency</b>	Standard: 24bit/48kHz, HD mode: 24bit/48kHz
<b>Encryption method</b>	AES128
<b>Max. simultaneous use</b>	Standard: 10 channels, HD mode: 20 channels (Depends on the region and environment)

**ATW-R1440****ATW-RC14**

<b>Receiver unit external connection port</b>	RJ45
<b>NETWORK Port</b>	RJ45: RJ45 Fast Ethernet
<b>LINK IN/OUT port</b>	RJ12
<b>Output Level</b>	LINE max: +22dBu (+20dBV), LINE Unity: -20dBu (-22dBV), MIC max: -12dBu (-10dBV), MIC Unity: -50dBu (-52dBV)
<b>Power consumption</b>	3.7W
<b>Power supply</b>	DC12V 0.5A (AC adapter)
<b>Operating temperature</b>	0°C to +40°C
<b>Dimensions</b>	209.8mm x 165.6mm x 42.5mm (W x D x H)
<b>Weight</b>	740g
<b>Included accessory</b>	Blade tip for AC adapter and AC adapter, Rack mount adapter (short), Rack mount adapter (long), Fixing screws x 5, Connecting cable (30cm), Rubber feet x 4

**ATW-RU14**

<b>Modulation mode</b>	GFSK
<b>RF output</b>	10mW EIRP
<b>RF sensitivity</b>	-90dBm typical
<b>Whip antenna</b>	1/2 Dipole Antenna Diversity
<b>External connection port</b>	RJ45
<b>Power supply</b>	DC12V (RC14)
<b>Operating temperature</b>	0°C to +40°C
<b>Dimensions</b>	86.0mm x 70.2mm x 18.7mm (W x D x H)
<b>Weight</b>	77g

**ATW-T1401**

<b>Modulation mode</b>	GFSK
<b>RF output</b>	10mW EIRP
<b>RF sensitivity</b>	-90dBm typical
<b>Whip antenna</b>	True diversity
<b>Input connection</b>	Four pin locking connector: Pin 1: GND, Pin 2: INST INPUT, Pin 3: MIC INPUT, Pin 4: DC BIAS +10V
<b>Battery</b>	DC3V (2 AA batteries)
<b>Operating temperature</b>	5°C to +40°C
<b>Battery Life</b>	AA alkaline batteries: Approx. 15 hours, AA nickel-hydrogen batteries: Approx. 14 hours and 30 minutes, AA lithium batteries: Approx. 29 hours (Varies depending on usage conditions)
<b>Dimensions</b>	63.7mm x 22.7mm x 107.4mm (W x D x H)
<b>Weight</b>	80g (without batteries)

**ATW-T1402**

<b>Modulation mode</b>	GFSK
<b>RF output</b>	10mW EIRP
<b>RF sensitivity</b>	-90dBm typical
<b>Whip antenna</b>	True diversity
<b>Microphone type</b>	Dynamic type
<b>Microphone Directional Characteristics</b>	Hypercardioid
<b>Battery</b>	DC3V (2 AA batteries)
<b>Operating temperature</b>	5°C to +40°C
<b>Battery Life</b>	AA alkaline batteries: Approx. 18 hours, AA nickel-hydrogen batteries: Approx. 16 hours and 30 minutes, AA lithium batteries: Approx. 35 hours (Varies depending on usage conditions)
<b>Dimensions</b>	265.0mm x 53.7mm
<b>Weight</b>	300g
<b>Included accessory</b>	Microphone holder AT8456a, Conversion screw adapter (3/8 - 5/8)

**ATW-T1406**

<b>Modulation mode</b>	GFSK
<b>RF output</b>	10mW EIRP
<b>RF sensitivity</b>	-90dBm typical
<b>Whip antenna</b>	True diversity
<b>Maximum input sound pressure level</b>	139dB SPL
<b>Microphone type</b>	Capacitor type
<b>Microphone Directional Characteristics</b>	Cardioid
<b>Operating temperature</b>	5°C to +40°C
<b>Built-in battery</b>	3.7V lithium-ion battery (5.5Wh 1460mAh)
<b>Battery Life</b>	Approx. 12 hours (Varies depending on usage conditions)
<b>Charging time</b>	Approx. 3 hours and 10 minutes (Varies depending on usage conditions)
<b>USB Charging Port</b>	USB Type-C (USB 2.0)
<b>Dimensions</b>	90.5mm x 129.4mm x 31.9mm (W x D x H)
<b>Weight</b>	510g (including battery)
<b>Included accessory</b>	USB power adapter, Blade tip for USB power adapter, USB cable (1.5 m)

**ATW-T1407**

<b>Modulation mode</b>	GFSK
<b>RF output</b>	10mW EIRP
<b>RF sensitivity</b>	-90dBm typical
<b>Whip antenna</b>	True diversity
<b>Microphone</b>	Gooseneck microphone support
<b>Phantom power supply</b>	DC24V
<b>Operating temperature</b>	5°C to +40°C
<b>Built-in battery</b>	3.7V lithium-ion battery (5.5Wh 1460mAh)
<b>Battery Life</b>	Without LED: Approx. 12 hours, With LED: Approx. 8 hours (Varies depending on usage conditions)
<b>Charging time</b>	Approx. 3 hours and 10 minutes (Varies depending on usage conditions)
<b>USB Charging Port</b>	USB Type-C (USB 2.0)
<b>Dimensions</b>	90.5mm x 129.4mm x 47.6mm (W x D x H)
<b>Weight</b>	490g (including battery)
<b>Included accessory</b>	USB power adapter, Blade tip for USB power adapter, USB cable (1.5 m)



## AT-One

Wireless System

### Easy to use

AT-One is designed with simplicity and ease-of-use in mind. Equipped with a practical carrying case, rack-mount kit and detachable antenna, AT-One is the perfect balance of price and performance, ideal for those looking for accurate, reliable performance at an entry-level price.

The AT-One's frequency plan is divided into two groups with four available channels in each group. All four channels in a group can be used simultaneously.

### Cardioid condenser capsule – induction loop ready

The condenser microphone capsule in the ATW-T1 handheld transmitter prevents inductive feedback from nearby hearing loops.

### 12V antenna power

The ATW-R1 receiver delivers a bias voltage of 12V / 100mA from each BNC antenna input, enabling the use of antenna boosters or other active components.



cW-Connector



front

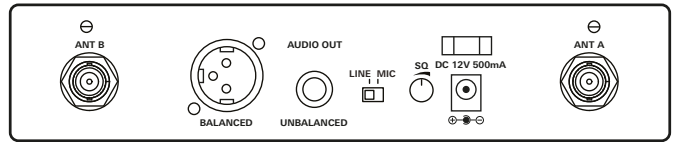

back

/ Receiver  
**ATW-R1**



Locking 4-pin microphone connector for use with Audio-Technica cW-style wireless body-pack transmitters.

/ Body-pack Transmitter  
**ATW-T1**



/ Handheld Transmitter  
**ATW-T3**

**AT-One**

<b>Operating Frequencies</b>	Band DE3: 482.625 to 511.375 MHz Band HH2: 824.400 to 830.850 MHz & 863.300 to 864.700 MHz
<b>Max. Number of Channels</b>	2 x 4
<b>Modulation Mode</b>	FM
<b>Operating Range</b>	60 m

**ATW-R1**

<b>Receiving System</b>	Antenna switching diversity
<b>Image Rejection</b>	55 dB minimum
<b>Sensitivity</b>	10 dB $\mu$ V (S/N 60 dB @ 20 kHz deviation)
<b>Maximum Output Level</b>	XLR, balanced, +4 dBV - 6.3 mm (1/4), unbalanced: -2 dBV
<b>Antenna Input</b>	BNC-type, 50 ohms 12 V DC, 100 mA (each)

**ATW-T1**

<b>Frequency Response</b>	60 to 16,000 Hz
<b>Dynamic Range</b>	103 dB or higher (A-weighted), typical
<b>Input Connection</b>	cW-style lock-down 4-pin connector
<b>Spurious Emissions</b>	Following federal and national regulations
<b>Maximum Deviation</b>	$\pm$ 40 kHz (THD:10%)
<b>Total Harmonic Distortion</b>	1.0 % or less (at 1 kHz, -20 kHz deviation)
<b>RF Power Output</b>	10 mW
<b>Battery Life</b>	10 hours (alkaline)
<b>Dimensions</b>	66 mm x 98 mm x 22 mm (W x D x H)
<b>Net Weight</b>	Approx. 71 g

**ATW-T3**

<b>Frequency Response</b>	60 to 16,000 Hz
<b>Dynamic Range</b>	108 dB or higher (A-weighted), typical
<b>Microphone Element</b>	Cardioid, condenser
<b>Spurious Emissions</b>	Following federal and national regulations
<b>Maximum Deviation</b>	$\pm$ 40 kHz (THD:10%)
<b>Total Harmonic Distortion</b>	1.0 % or less (at 1 kHz, -20 kHz deviation)
<b>RF Power Output</b>	10 mW
<b>Battery Life</b>	10 hours (alkaline)
<b>Dimensions</b>	268 mm long, 52 mm maximum diameter
<b>Net Weight</b>	277 g



/ AT-One -  
Body-pack System  
**ATW-11**



/ AT-One -  
Handheld System  
**ATW-13**

Connected Accessory		ATW-A49a	ATW-A410P	ATW-B80WB	ATW-SC410	ATW-DA49a
Current Requirement		0 mA	60mA	60mA	0 mA	0 mA
Used wireless system		Current per antenna input @12V				
AT-One	ATW-R1	100 mA	+	1 pair	1 pair	+
2000 Series	ATW-R2100	60 mA	+	1 pair	1 pair	+
3000 Series	ATW-R3210	80 mA	+	1 pair	1 pair	+
System 20	All receiver	-	-	-	-	-
Distribution amplifier	ATW-DA49A	250 mA	+	2 pair (**)	4 pair	+

(\*\*) You would require to use a pair of ATW-SC410 to connect 2 pairs of antennas.  
 Please use the above table to determine the maximum numbers of active componets in the antenna cable run.  
 Example: AT-One (100 mA per antenna cable run) could drive 1 pair of ATW-B80WB boosters and 1 pair of ATW-SC410 splitter. (60 mA + 0 mA = 60 mA).  
 Example: ATW-DA49a (250 mA per antenna cable run) could drive 2 pairs of ATW-A49a (0 mA), 2 pairs of ATW-B80WB boosters (2x 60mA per antenna run) and 1 pair of ATW-SC410 (0 mA): Total 2x 120 mA.

# ATW-DA49a

## UHF Antenna Distribution Systems



### Durability

The ATW-DA49a provides a high OIP3 (+ 32 dBm) for maximum protection against intermodulation.

#### Specifications

	ATW-DA49a
Antenna Power (optional)	12V DC, 250 mA (combined)
Current Consumption	200 mA ± 50 mA at 12 V DC
Gain	+1.0dB typical (within specified bandwidth)
Input	2 x 1 inputs
OIP3	+32dBm typical (within specified bandwidth)
Output	2 x 4 outputs + 1 cascade output - BNC Female
Operating Bandwidth	470-990 MHz
Power Supply	100-240V AC (50/60 Hz) to 12V DC 1A (centre positive) switched mode external power supply

### / UHF Passive Splitter/Combiner ATW-SC410



#### Specifications

	ATW-SC410
Description	UHF Passive Splitter/Combiner
Frequency Range	470 to 990 MHz
Impedance	50 ohms
High Frequency Transmission Loss	2 dB (typical)
Current Pass Through	420 mA
Connections	BNC-J x 3
Dimensions	100 mm × 99.8 mm × 30 mm (W × D × H)
Weight	204 g



/ UHF Wide-Band Directional LPDA Antennas (pair)  
**ATW-A49a**

Specifications	ATW-A49a
Antenna Type	Log Periodic Dipole Array (LPDA)
Operating Bandwidth	470 – 950 MHz
Gain	6 dBi typical*
Impedance	50 ohms typical*
VSWR	≤ 1.7*
Polar Pattern	100°, 3 dB beam width
Polarization	Vertical (when mounted vertically)
Number of Elements	9
Maximum Power Input	Not specified (intended as receive antenna only)
Termination Type	Fixed right-angle BNC female Connector is positioned to minimize cable strain
Weight	316 g each
Dimensions	268 mm L x 285 mm H x 30 mm D
Material	Copper-clad epoxy fiberglass



/ UHF Powered Wideband Antenna (single)  
**ATW-A410P**

Specifications	ATW-A410P
Gain	-10 dB / 0 dB / +6 dB / +12 dB
OIP3	> 30 dBm typical (within specified bandwidth)
Termination Type	BNC-J
Operating Bandwidth	470-990 MHz
Operating Temperature Range	-10°C to 50°C
Dimensions	175 x 175 x 50 mm (without bracket)
Weight	390 g (without bracket)
Accessories	Mounting bracket, screws
Impedance	50 ohms typical (within specified bandwidth)
Power Consumption	60mA



/ In-Line RF booster 470-990MHz 6dB / 12dB (pair)  
**ATW-B80WB**

Specifications	ATW-B80WB
Connections	BNC-J (IN), BNC-J (OUT)
Power Supply	DC 12V
Frequency Range	470 - 990 MHz
Impedance	50 ohms
Power Consumption	60mA
Gain High	+12 dB Red, +6 dB Green



RF Antenna Cables	Length
AC90 (pair)	0.9 m
AC300	3 m
AC600	6 m
AC1000	10 m
AC2000	20 m
AC4000	40 m

---

/ Antenna Front-Mount Kit  
**ATW-AF1**

*For ATW-DA49a*



---

/ Universal Joining Plate for AT 9.5" devices  
**AT8631**

*For ATW-R3210, ATW-R3210N, ATW-R2100b,  
ATW-R1300, ATW-R1310, ATW-R1320  
and other AT 9.5" devices*

---

/ 3.5 mm - XLR Cable (ATW-R1700)  
**AT8350**



---

/ Camera Shoe Dual Mount  
**AT8691**

*For System 20, ATW-R1700*



---

/ 9.5" devices only -  
**ATW-RM1b**

*Rack-mount Hardware Kit*



---

/ Antenna Front-Mount Kit  
**ATW-AF2**

*19"/1RU RXs:  
ATW-R5220,  
ATW-DR3120*



---

/ Dual Rack-Mount Kit  
**AT8677**









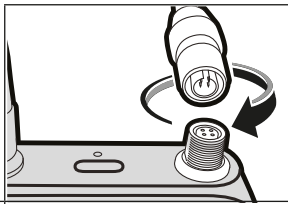
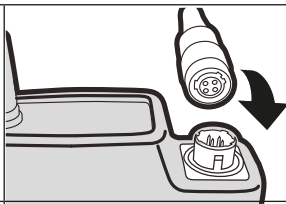

*For AT-One, ATW-R1*

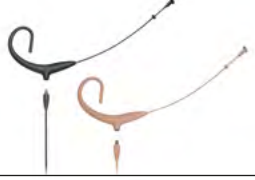







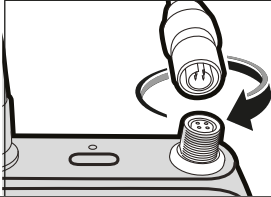
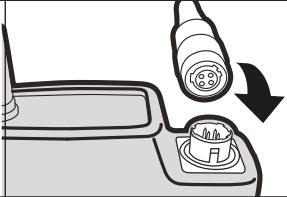

---

/ 3.5 mm - 3.5 mm Cable (ATW-R1700)  
**AT8349**



		cH-Version	cW-Version
			
	/ Subminiature Omnidirectional Condenser Headworn Microphone	<b>BP892xcH</b> ⊗ <b>BP892xcH-TH</b>	<b>BP892xcW</b> ⊗ <b>BP892xcW-TH</b>
	/ Subminiature Cardioid Condenser Headworn Microphone	<b>BP894xcH</b> ⊗ <b>BP894xcH-TH</b>	<b>BP894xcW</b> ⊗ <b>BP894xcW-TH</b>
	/ Subminiature Cardioid Condenser Lavalier Microphone	<b>BP898cH</b>	<b>BP898cW</b>
	/ Subminiature Omnidirectional Condenser Lavalier Microphone	<b>BP899cH</b> ⊗ <b>BP899cH-TH</b>	<b>BP899cW</b> ⊗ <b>BP899cW-TH</b>
	/ Cardioid Condenser Headworn Microphone	<b>ATM73cH</b>	<b>ATM73cW</b>
	/ Cardioid Condenser Headworn Microphone	<b>ATM75cH</b>	<b>ATM75cW</b>
	/ Hypercardioid Dynamic Headworn Microphone	<b>PRO8HEcH</b>	<b>PRO8HEcW</b>
	/ Cardioid Condenser Headworn Microphone	<b>PRO9cH</b>	<b>PRO9cW</b>
	/ Omnidirectional Condenser Headworn Microphone	<b>PRO92cH</b> ⊗ <b>PRO92cH-TH</b>	<b>PRO92cW</b> ⊗ <b>PRO92cW-TH</b>

		cH-Version	cW-Version
			
	/ Miniature Cardioid Condenser Lavalier Microphone	<b>AT831cH</b>	<b>AT831cW</b>
	/ Miniature Omnidirectional Condenser Lavalier Microphone	<b>AT803cH</b>	<b>AT803cW</b>
	/ Cardioid Condenser Lavalier Microphone	<b>AT829cH</b>	<b>AT829cW</b>
	/ Omnidirectional Condenser Lavalier Microphone		<b>MT838cW</b>
	/ Omnidirectional Condenser Lavalier Microphone	<b>MT830cH</b>	<b>MT830cW</b>
	/ Omnidirectional Condenser Lavalier Microphone		<b>ATR35cW</b>

		cH-Version	cW-Version
			
	<p>/ Cardioid Condenser Instrument Microphone w/ Universal Clip-on Mounting System</p>	<p><b>ATM350UcH</b></p>	<p><b>ATM350UcW</b></p>
	<p>/ Cardioid Condenser Clip-on Instrument Microphone</p>	<p><b>PRO35cH</b></p>	<p><b>PRO35cW</b></p>
	<p>/ Professional Guitar Input Cable</p>	<p><b>AT-GcH PRO</b></p>	<p><b>AT-GcW PRO</b></p>
	<p>/ Professional Guitar Input Cable Angled</p>	<p><b>AT-GRcH PRO</b></p>	<p><b>AT-GRcW PRO</b></p>
	<p>/ Guitar Input Cable</p>	<p><b>AT-GcH</b></p>	<p><b>AT-GcW</b></p>
	<p>/ Microphone Input Cable</p>	<p><b>XLRcH</b></p>	<p><b>XLRW</b></p>
	<p>/ Adapter Cable cW-mics to cH-belt-pack TXs</p>	<p><b>AT-cWcH</b></p>	

## Dual-channel wireless system

When more than one wireless microphone system is required, you may find that in certain circumstances using two receivers side-by-side with individual antennas is unsuitable. For example, where the receiver needs to be placed out of sight or in a different room, such as installation for a multi-purpose venue, house of worship or a small live music performance.

The solution is to utilise one pair of antennas placed in the room to feed both the receivers. The signal is passed from the room over two 50 Ohm RF cables to the receivers' location, where the antenna signals are split into each receiver using the ATW-SC410 Active Antenna Splitter Kit.

Check the signal loss of the antenna cable, based on the frequency range of your system and the specified antenna cable length and type. Audio-Technica's wireless manager software offers a "cable loss calculation tool" to do so. If the dB loss exceeds 7 dB, you should consider including the ATW-B80WB In-Line RF Booster as each 6dB of loss across the signal chain will reduce your systems operating distance by 50%.

The ATW-SC410 is powered by the receivers across the antenna cable – no external power source is required. Though our example includes the ATW-A49 LPDA Antenna, any passive antennas can be used provided they support the frequency range of your wireless systems.

If you require an active antenna like our ATW-A410P, or other active components such as the ATW-B80WB, then check the total current consumption of the individual products (simply add their stated mA together per RF cable run) to make certain that your receiver delivers the necessary power.

Compatible Audio-Technica wireless systems for this solution include the AT-One, 2000 Series and 3000 Series.

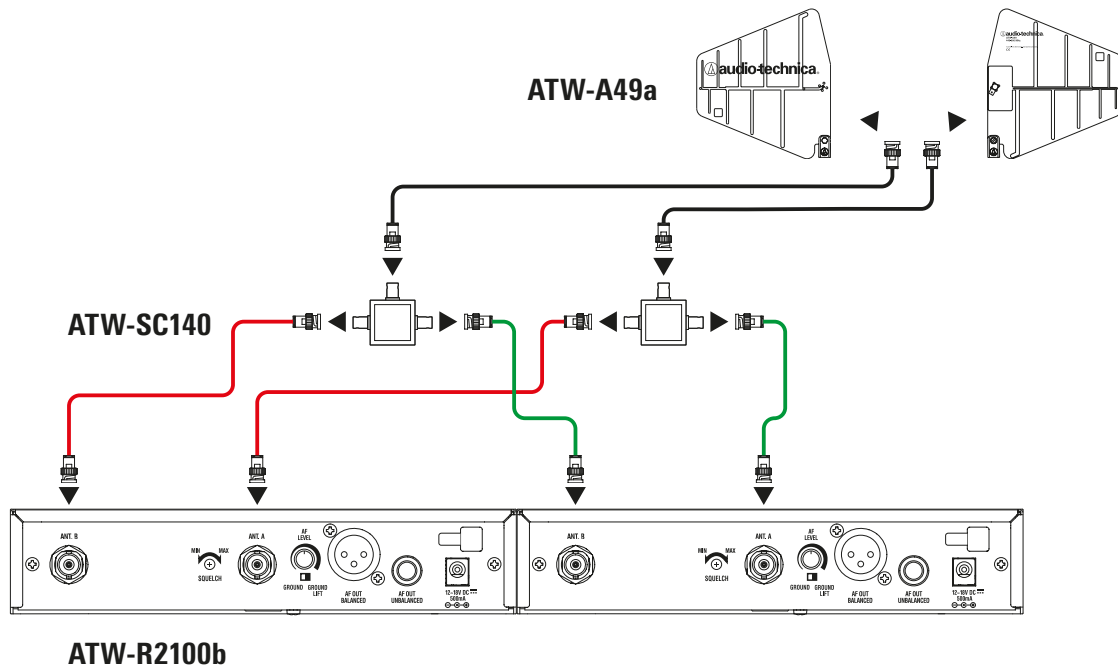

## Product table

Quantity	Code	Description	Alternative
2	<b>ATW-R2100b</b>	Frequency-agile True Diversity UHF Wireless Receiver	
2	<b>ATW-T210a</b>	2000a Series UniPak™ Transmitter	ATW-T220a Handheld Transmitter
1	<b>ATW-A49a</b>	Pair of UHF Wide-band Directional LPDA Antennas	
1	<b>ATW-SC410</b>	Passive Antenna Splitter Kit	
2	<b>AC90</b>	90cm RG58 Antenna Cable (Pair)	AC300, AC600, AC1000, AC2000, AC4000

## Single-channel wireless system covering two zones

In some situations, only one wireless system is required, but there is the need to guarantee coverage over two separate areas. This, in most cases, is simply not achievable using one pair of antennas. An example of this would be when needing to cover an indoor area and its associated outdoor space, such as you may find in a restaurant, bar, or house of worship setting. Alternatively, a client may have a hotel ballroom which also divides into two multi-function areas, resulting in the need to cover the sections individually.

To achieve this solution, you will need two pairs of antennas – one pair per area requiring coverage. Then, the four antenna cables run to the receiver location, and they are combined using the ATW-SC410 Antenna Combiner Kit. The resulting two antenna cables can then connect directly to the wireless receiver. Take care to position the ATW-SC410 as close to the antennas as possible, to minimise the quantity of antenna cable required in the installation – this will improve signal integrity and reduce cost for the customer. Refer to the notes in Application 1 for advice on specifying cable length, active antennas and boosters in the cable run.

If the receiver in use can provide adequate current, it is possible to combine Application 1 and Application 2 to create a dual-channel wireless solution with the ability to cover two zones.

Compatible Audio-Technica wireless systems for this solution include the AT-One, 2000 Series, 3000 Series and 5000 Series.

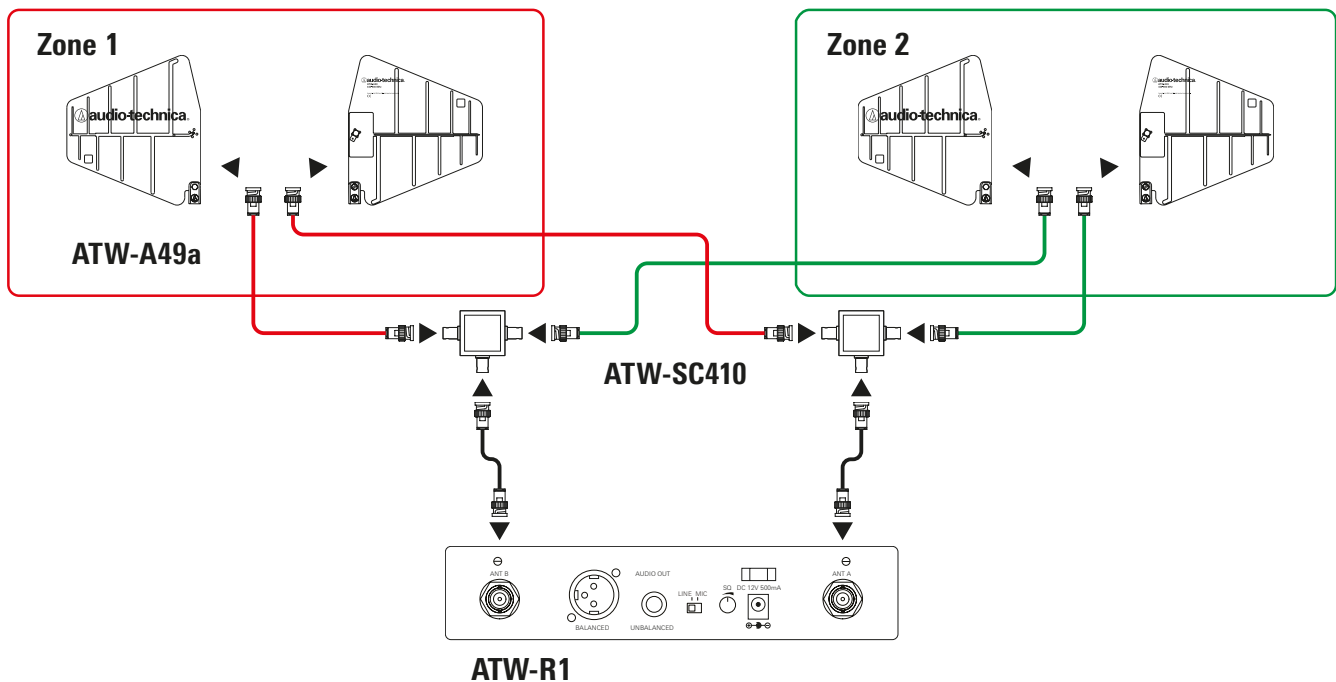

## Product table

Quantity	Code	Description	Alternative
1	ATW-R1	Diversity UHF Wireless Receiver	
1	ATW-T1	AT-One Beltpack Transmitter	ATW-T3 Handheld Transmitter
2	ATW-A49a	Pair of UHF Wide-band Directional LPDA Antennas	
1	ATW-SC410	Active Antenna Combiner Kit	
4	AC90	90cm RG58 Antenna Cable (Pair)	AC300, AC600, AC1000, AC2000, AC4000

## Multiple zones wireless system

If you need to cover more than two areas which are in proximity of one another, or you simply need to cover one very large area, then this solution may suit your requirements. Consider the need for a wireless microphone which needs to operate throughout the areas of a shopping mall, or over the very wide area of a sports venue – such as a golf course.

Initially, you may consider using multiple pairs of antennas, combining them with multiple ATW-SC410. However, this is not usually the best approach, as you will either run into power issues or the total cable runs will become too long to compensate for incurred RF loss with signal boosters.

This application offers a more elegant solution. The concept begins with placing a wireless receiver of the same type, tuned to the same frequency, in each area with a local pair of antennas.

If you were to use these receivers alone, you could operate the transmitter in each room, provided you activate only one receiver at a time. Then, the audio signal can be sent from the active receiver to the local speaker system as needed. In this scenario, you must manually switch off or mute the unused receivers in order to avoid erratic audio signals being output whilst the wireless transmitter is out of range.

In most cases, this option is not practical. It may not be possible to continually ensure unused receivers are switched off between uses, or a project may demand that the wireless transmitter must work across all areas freely – without continual adjustment by a technician.

The solution is to add the ATDM-0604a Digital SmartMixer. Simply connect the audio signals from each receiver to the ATDM-0604a and set the unit to Smart Mix mode, making sure to allow only one open microphone at a time. This way, a receiver remains active in the mixer until an audio drop out occurs, which will trigger the mixer to automatically switch to the receiver featuring the most reliable signal. With this solution, you can combine up to six areas, whilst creating one reliable output signal.

Check Application 1 for important information on total cable length, active antennas or using boosters in your antenna cable run. It is possible to combine Application 3 with Application 2 in some or all zones to increase the area of coverage even further. Also, it is possible to combine Application 3 with Application 4. In this case, you will require one ATDM mixer for each wireless microphone you want to use.

Compatible Audio-Technica wireless systems for this solution include the AT-One, 2000 Series and 3000 Series.



## Product table

Quantity	Code	Description	Alternative
6	<b>ATW-R2100c</b>	Frequency-Agile True Diversity UHF Wireless Receiver	
1	<b>ATW-T210c</b>	2000 Series Beltpack Transmitter	ATW-T220c Handheld Transmitter
1	<b>ATDM-0604a</b>	Digital SmartMixer	

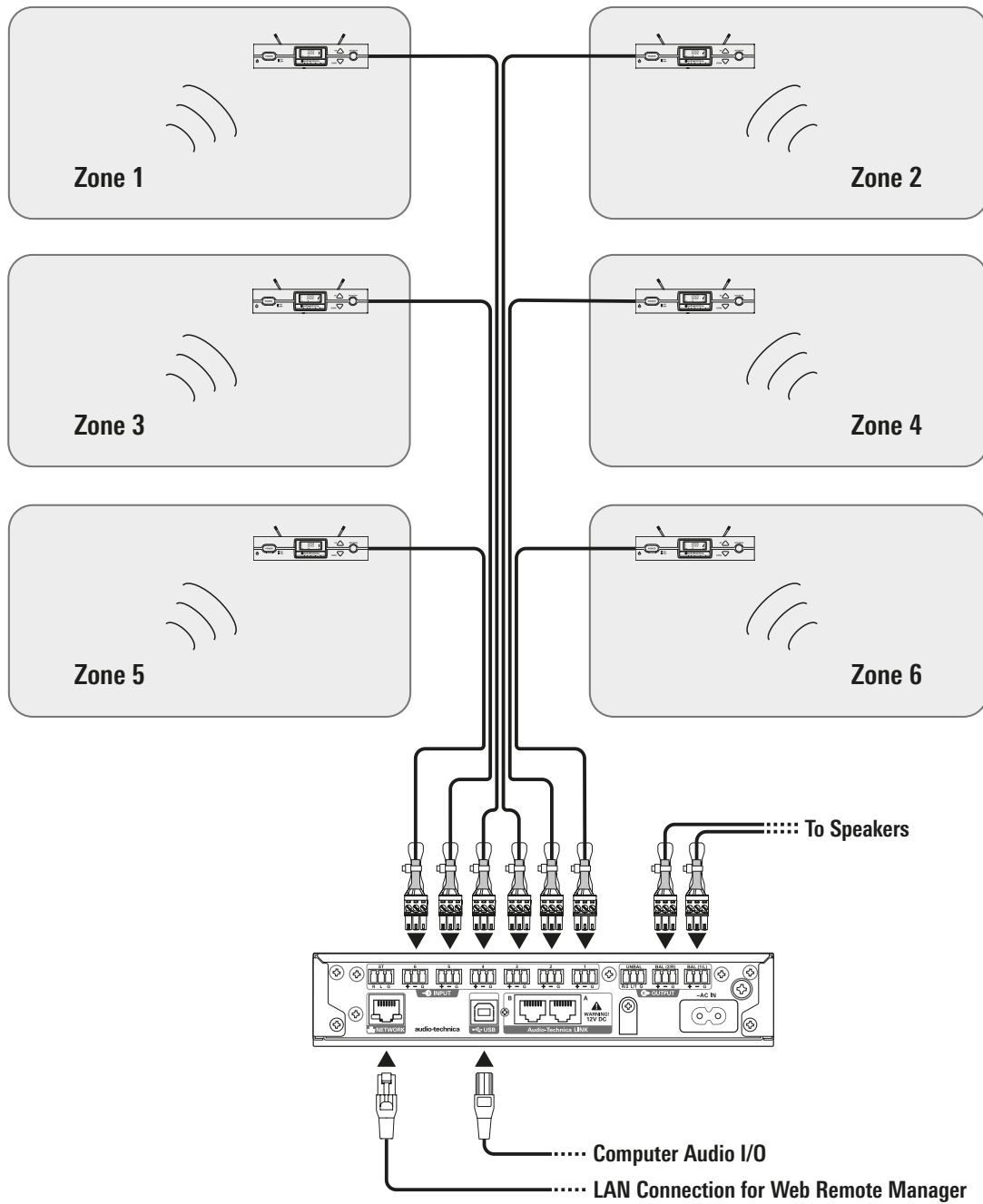

**Equipment used**

**ATDM-0604a**



**6 x ATW-R2100c**



**ATW-T210c**

**1 x**

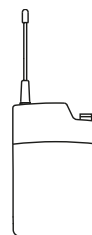

**or**

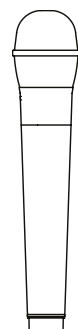

## Four-channel wireless system

A four-channel wireless system is often required by live music acts, podium discussions, or in fixed installations for multi-purpose rooms. Rental companies may also design their wireless systems in blocks of four channels for small to medium sized events, as these racks are easy to handle whilst being easily scaled up to a larger system when required (see Application 6).

This solution is similar in design to Application 1. The primary difference is the inclusion of the ATW-DA49a, which can divide the incoming pair of antenna signals into four individual signal pairs to feed each receiver. However, this change does not only offer more outputs. In Application 1, the ATW-SC410 is powered by the receiver, while in this setup the ATW-DA49a is powered by mains voltage. As a result, the ATW-DA49a distribution amplifier can provide significantly more antenna power for active components in the cable run. Due to the higher current this unit can deliver, it is possible to realise much longer cable runs, with more than one ATW-B80WB booster, as well as drive antenna combiners and active antennas before reaching a power limitation.

Check Application 1 for important information on total cable length, active antennas or using boosters in your antenna cable run. This application can be combined with Application 2 and is the core design for achieving Application 6.

Compatible Audio-Technica wireless systems for this solution include the AT-One, 2000 Series and 3000 Series.



## Product table

Quantity	Code	Description	Alternative
4	<b>ATW-R3210</b>	Frequency-Agile True Diversity UHF Wireless Receiver	ATW-R3210N
4	<b>ATW-T3201</b>	3000 Series Beltpack Transmitter	ATW-T3202 Handheld Transmitter
1	<b>ATW-DA49a</b>	UHF Antenna Distribution System	
1	<b>ATW-A49a</b>	Pair of UHF Wide-band Directional LPDA Antennas	ATW-A410P
1	<b>ATW-B80WB</b>	Pair of In-Line RF boosters 470-990MHz	
4	<b>AC90</b>	90cm RG58 Antenna Cable (Pair)	AC300, AC600, AC1000, AC2000, AC4000

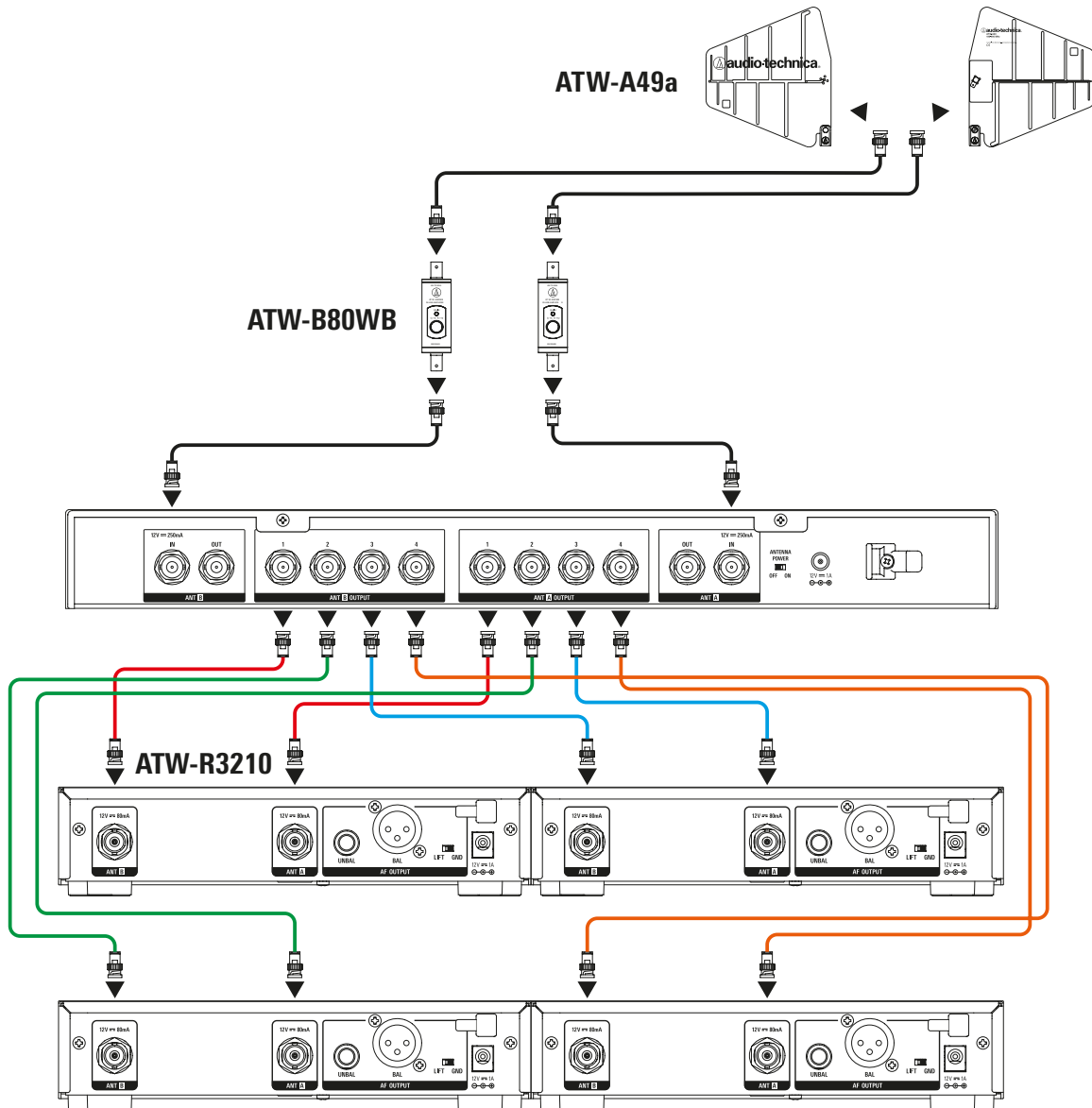

Equipment used

ATW-DA49a



ATW-A49a

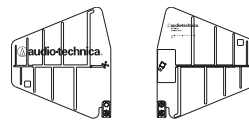

ATW-B80WB

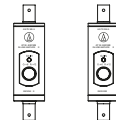

4 x ATW-R3210

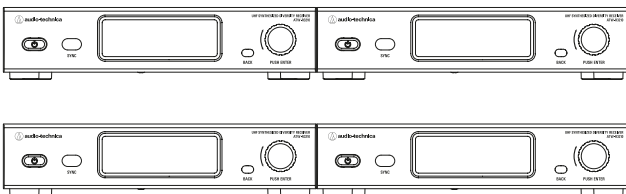

ATW-T3201a

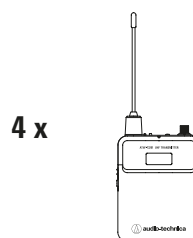

ATW-T3202a

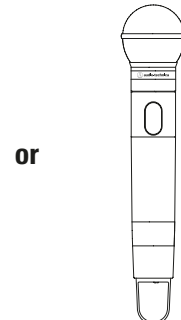

4 x

or

## System 10 PRO Multi-channel wireless system for install

This solution is aimed at fixed installations where the use of UHF TV bands is not preferred, such as in locations with a restricted RF environment or where the customer wishes to avoid licensing costs and the need for frequency coordination. Typical applications for this include educational facilities such as schools or universities, multi-function rooms, or conference centres.

This application is based around our System 10 Pro wireless system. System 10 does not use the UHF TV band frequency spectrum (470 - 865 MHz) associated with our other wireless products but operates on the 2.4GHz spectrum, most used for WLAN and Bluetooth® transmission. 2.4GHz offers many benefits, but you must also consider its limitations when using it for wireless audio.

The immediate advantage is that System 10 Pro is completely license free in almost all countries and requires no frequency planning by the installer or operator. However, due to the small wavelength of the 2.4GHz signal (around 12cm), the operating range is shorter than our other wireless systems which use the lower UHF range. This solution is not ideal for open-air scenarios, where long operating distance is required.

However, reduced operating range can also have benefits. For example, if multiple rooms located side-by-side all require a dedicated wireless system, you can reuse the same spectrum by using System 10 Pro in adjacent rooms – very little physical separation between rooms is required.

Another challenge with the 2.4GHz range is the parallel use of Wi-Fi alongside our wireless system. In this case, it is recommended to utilise 5.8GHz for Wi-Fi connectivity in place of 2.4GHz. If this is not possible, the placement of your wireless microphone receiver becomes very important. Here is why System 10 Pro offers the right solution.

2.4GHz antenna cables suffer from higher power losses over their cable run than UHF frequencies. At the same time, many installers do not wish to locate audio racks of receivers in the meeting room, but instead place them in a separate A/V room with the audio mixer and other equipment.

With System 10 Pro, the ATW-RU13 receiver unit can be removed and mounted remotely, connecting to the ATW-RC13 via standard ethernet cable. The ATW-RC13 can stay in the audio rack, whilst the ATW-RU13 can be mounted up to 100m away – on a wall, in the presenter podium, or hidden above the false ceiling in the room. The ATW-RU13 receiver unit is compact in size, and its included wall-mount housing can be painted in any colour to conceal it further.

Ensure to mount ATW-RU13 units as close as possible to the area where the wireless microphones will be used and aim to position any Wi-Fi access points at the opposite side of the room for maximum signal stability.

The compatible Audio-Technica wireless system for this solution is the System 10 Pro.



### Product table

Quantity	Code	Description	Alternative
3	ATW-R1320	System 10 Pro Dual Channel Receiver	
6	ATW-T1006	System 10 Boundary Microphone Transmitter	ATW-T1001, ATW-T1002, ATW-T1007
1	ATDM-0604a	Digital SmartMixer	

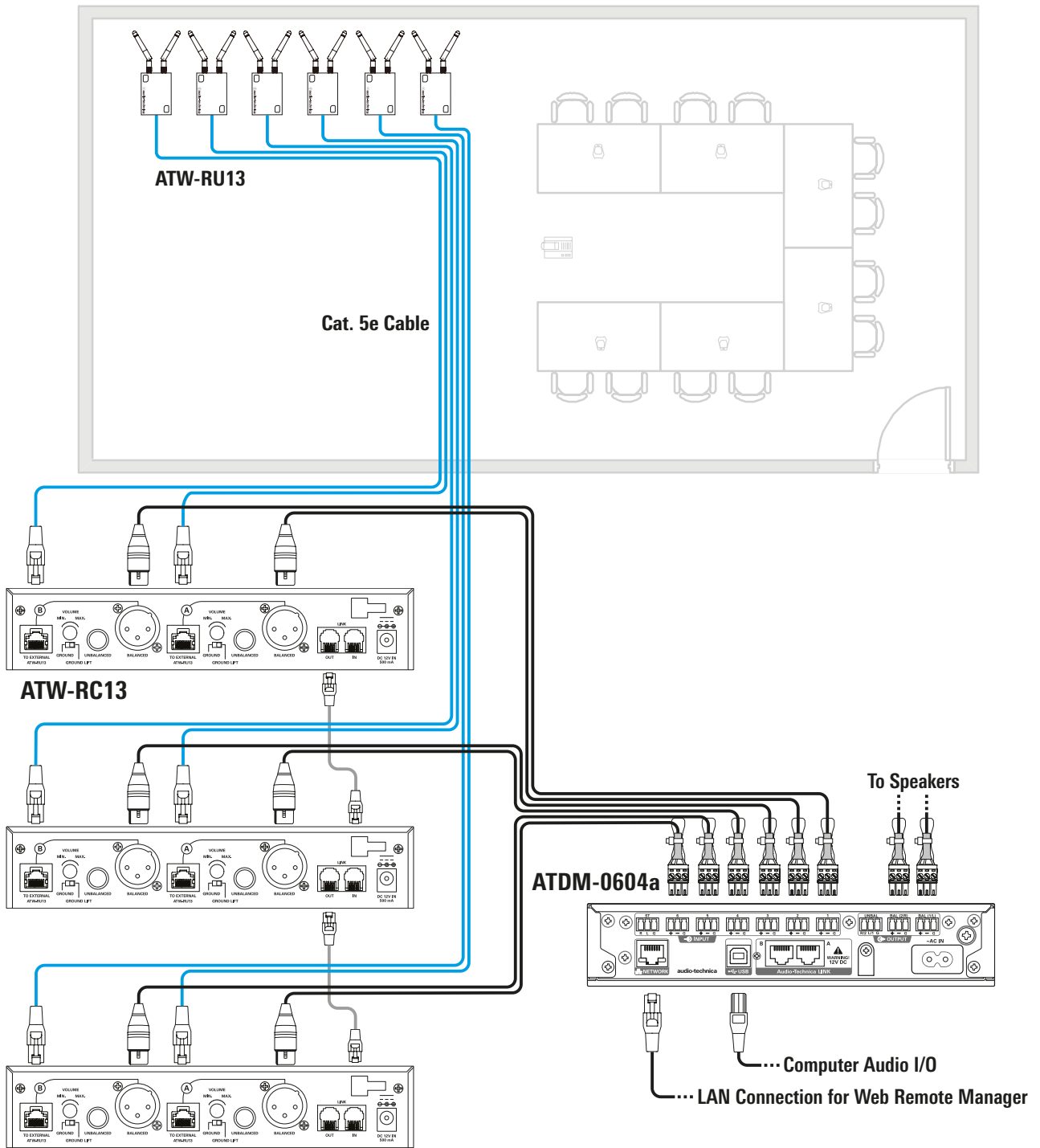

**Equipment used**

**ATDM-0604a**



**3 x ATW-R1320**

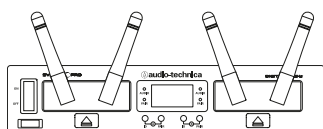

**ATW-T1001**



6x

**ATW-T1002**



or

**ATW-T1006**

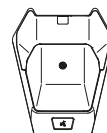

**ATW-T1007**



or

## 16-channel wireless system using ATW-DA49a

Where more than four wireless systems are required, this solution may be the answer. Typical applications include larger live bands, music festivals featuring multiple acts, theatre productions, larger conferences, and in sports broadcast where wireless microphones are used to collect sounds of the event.

This solution begins with the 4-channel system from Application 4. In this scenario, up to four of the 4-channel racks are used and then they are linked together using one ATW-DA49a UHF Antenna Distribution System, achieving 16 channels of wireless audio.

Note: pay special attention to the “star” topology wiring of this example: the top ATW-DA49a feeds the antenna inputs of the following four ATW-DA49a. This means that each antenna signal is passing through no more than two antenna distribution units before reaching the receiver.

Also, that the ATW-DA49a’s link output have not been used in this scenario. If only eight channels are required, it is acceptable to use the ATW-DA49a’s link output to pass the signal along to a second ATW-DA49a – the eight receivers then connect via each distributor’s antenna outputs. However, once more wireless systems are needed, it is best practice to implement the star topology given in this example to avoid unnecessary RF signal degradation.

This concept is easily scalable, making it ideal for rental companies, or businesses with flexible technical requirements. Several self-contained modules of four-channel systems can be used and then quickly combined using one additional ATW-DA49a, as and when required.

Refer to the notes in Application. 1 for advice on specifying cable length, active antennas and boosters in the cable run.

This application can be combined with Application 2 and relies on Application 4.

Compatible Audio-Technica wireless systems for this solution include the 2000 Series and 3000 Series.



### Product table

Quantity	Code	Description	Alternative
16	<b>ATW-R3210N</b>	Frequency-Agile True Diversity UHF Wireless Receiver	ATW-R3210
16	<b>ATW-T3201a</b>	3000 Series Beltpack Transmitter	ATW-T3202a Handheld Transmitter
5	<b>ATW-DA49a</b>	UHF Antenna Distribution System	
1	<b>ATW-A49a</b>	Pair of UHF Wide-band Directional LPDA Antennas	ATW-A410P
1	<b>ATW-B80WB</b>	Pair of In-Line RF boosters 470-990MHz	
4	<b>AC90</b>	90cm RG58 Antenna Cable (Pair)	AC300, AC600, AC1000, AC2000, AC4000

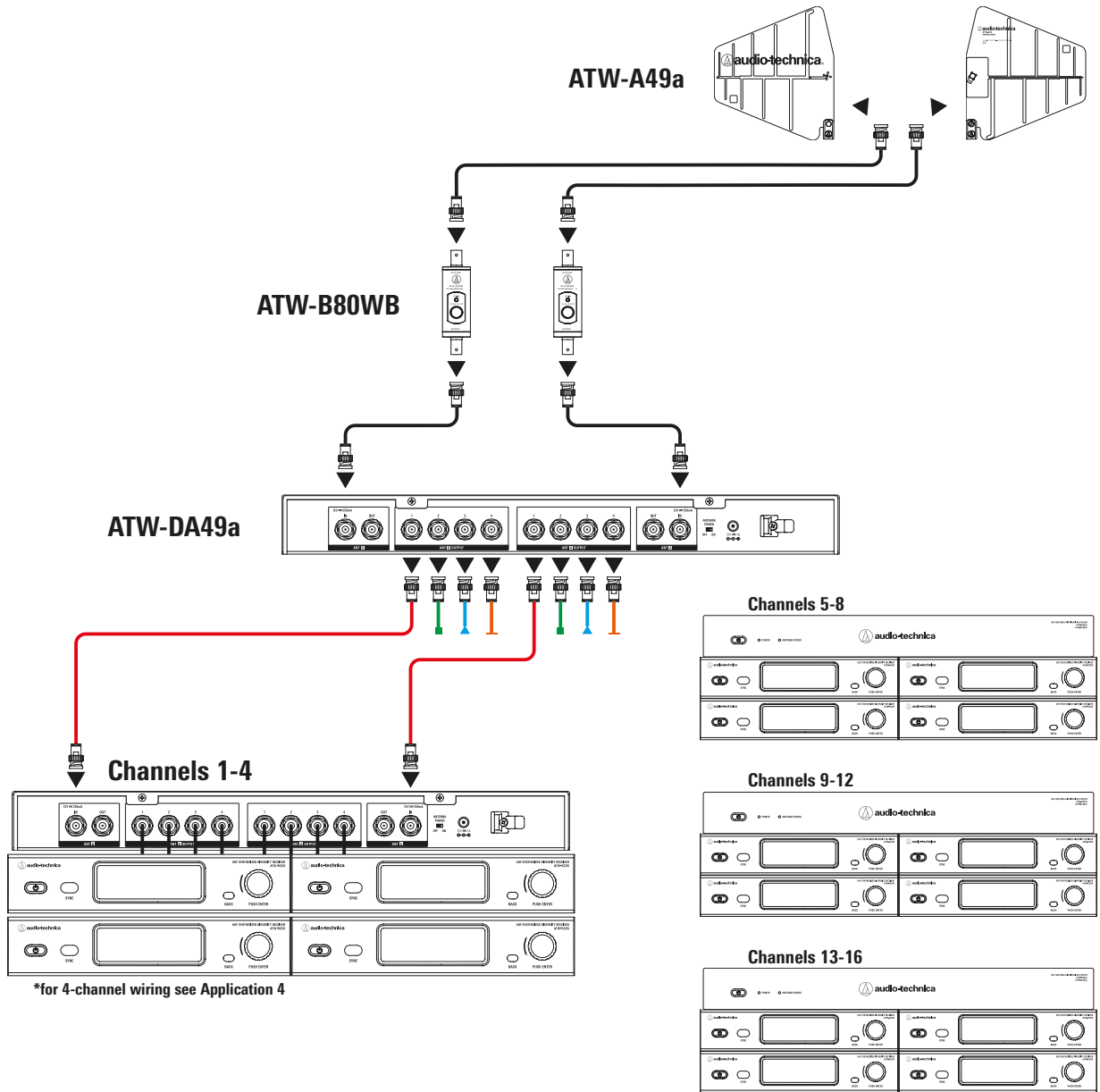

**Equipment used**

5 x ATW-DA49a



16 x ATW-R3210

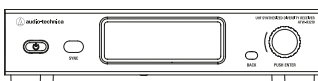

ATW-A49a

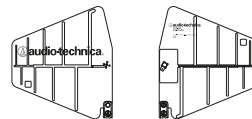

ATW-B80WB

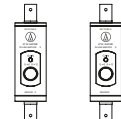

ATW-T3201a

16 x

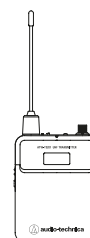

ATW-T3202a

or

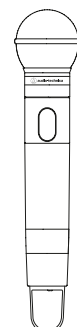

## 16-channel wireless system using daisy chain

If you require significant UHF flexibility for touring or are simply in need of a reliable wireless system with exceptional audio quality, the 5000 Series is ideal. Here the 5000 Series is used to achieve a 16-way system. This type of setup is commonly found in music festivals, touring rigs, or in smaller installations for theatre, sports and conferencing.

This is an alternative option to Application 6, consider both systems to determine which better suits the requirements.

Based around the 5000 Series, the key to this solution is the powerful antenna distribution amplifier built into the ATW-R5220 Dual Receiver. As seen in the diagram, the ATW-A49a antennas connect directly to the receivers without the need to pass through any external distribution units. Each ATW-R5220 then passes the RF signal along to the next receiver in a daisy-chain configuration. With this, up to eight dual-channel receivers can be combined in a simple and efficient way, providing 16 channels of wireless audio.

Pay special attention to the cable run in the diagram. The first antenna signal has been connected to the first receiver, passing down to the eighth receiver; meanwhile, the second antenna signal starts at the eighth receiver and works upwards. This method affords a degree of redundancy, as should any one receiver lose power the remaining units will continue to receive RF signal from at least one antenna.

Refer to the notes in Application 1 for advice on specifying cable length, active antennas and boosters in the cable run.

This Application can be combined with Application 2 and is essential to Application 8.

The compatible Audio-Technica wireless system for this solution is the 5000 Series.



### Product table

Quantity	Code	Description	Alternative
8	<b>ATW-R5220DAN</b>	5000 Series Dual Channel Receiver with Dante®	ATW-R5220
16	<b>ATW-T5201</b>	5000 Series Beltpack Transmitter	ATW-T5202 Handheld Transmitter
1	<b>ATW-A49a</b>	Pair of UHF Wide-band Directional LPDA Antennas	
1	<b>ATW-B80WB</b>	Pair of In-Line RF boosters 470-990MHz	
4	<b>AC90</b>	90cm RG58 Antenna Cable (Pair)	AC300, AC600, AC1000, AC2000, AC4000

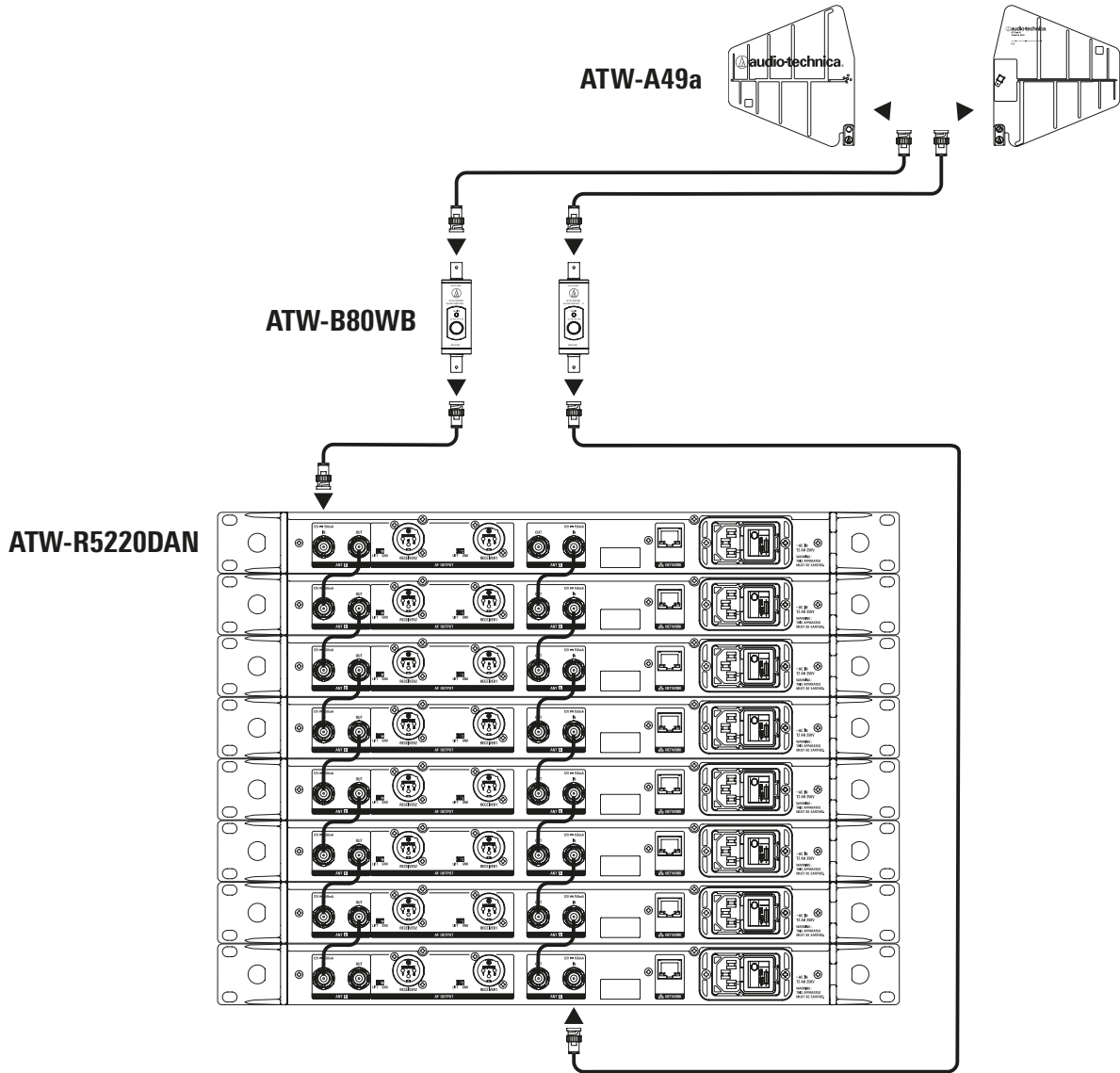

Equipment used

8 x ATW-R5220 / ATW-R5220DAN

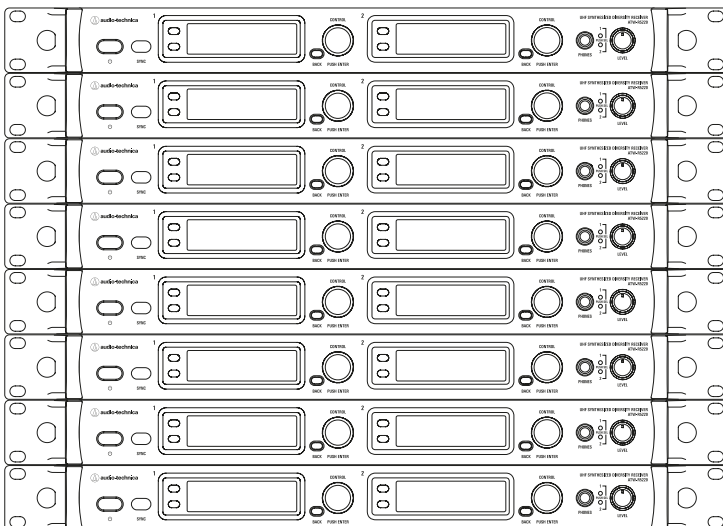

ATW-A49a

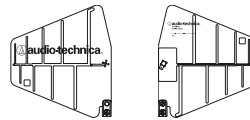

ATW-B80WB

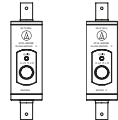

ATW-T5201

16 x

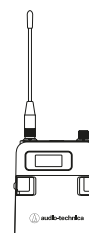

ATW-T5202

or

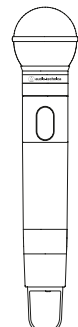

## 64-channel wireless system / 256-channel wireless system

This system is designed for large scale wireless audio projects, as found in theatre, opera, TV & sports broadcasting, music festivals or any application where high numbers of wireless systems are essential requirements.

This solution begins with the 16-way system shown in Application 7. Having constructed racks of eight dual receivers, one ATW-DA49a UHF Antenna Distribution System can be added. This should be placed after the antennas and linked to up to four of the 16-way racks, allowing for 64 simultaneous wireless audio channels.

Is 64-channels the limit? If more than 64-channels are required, the system can be considered as one “module”, and more can be added. Up to four 64-channel modules can then connect to one final ATW-DA49a, opening the possibility for a 256-channel wireless solution – all operating with just one pair of antennas.

Refer to the notes in Application 1 for advice on specifying cable length, active antennas and boosters in the cable run.

This Application can also combine with Application 2 and relies on Application 7.

The compatible Audio-Technica wireless system for this solution is the 5000 Series.

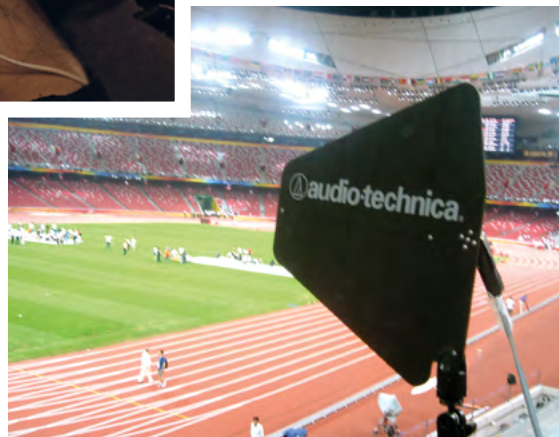

### Product table

Quantity	Code	Description	Alternative
32	<b>ATW-R5220DAN</b>	5000 Series Dual Channel Receiver with Dante®	ATW-R5220
64	<b>ATW-T5201</b>	5000 Series Beltpack Transmitter	ATW-T5202 Handheld Transmitter
1	<b>ATW-DA49a</b>	UHF Antenna Distribution System	
1	<b>ATW-A49</b>	Pair of UHF Wide-band Directional LPDA Antennas	
1	<b>ATW-B80WB</b>	Pair of In-Line RF boosters 470-990MHz	
4	<b>AC90</b>	90cm RG58 Antenna Cable (Pair)	AC300, AC600, AC1000, AC2000, AC4000

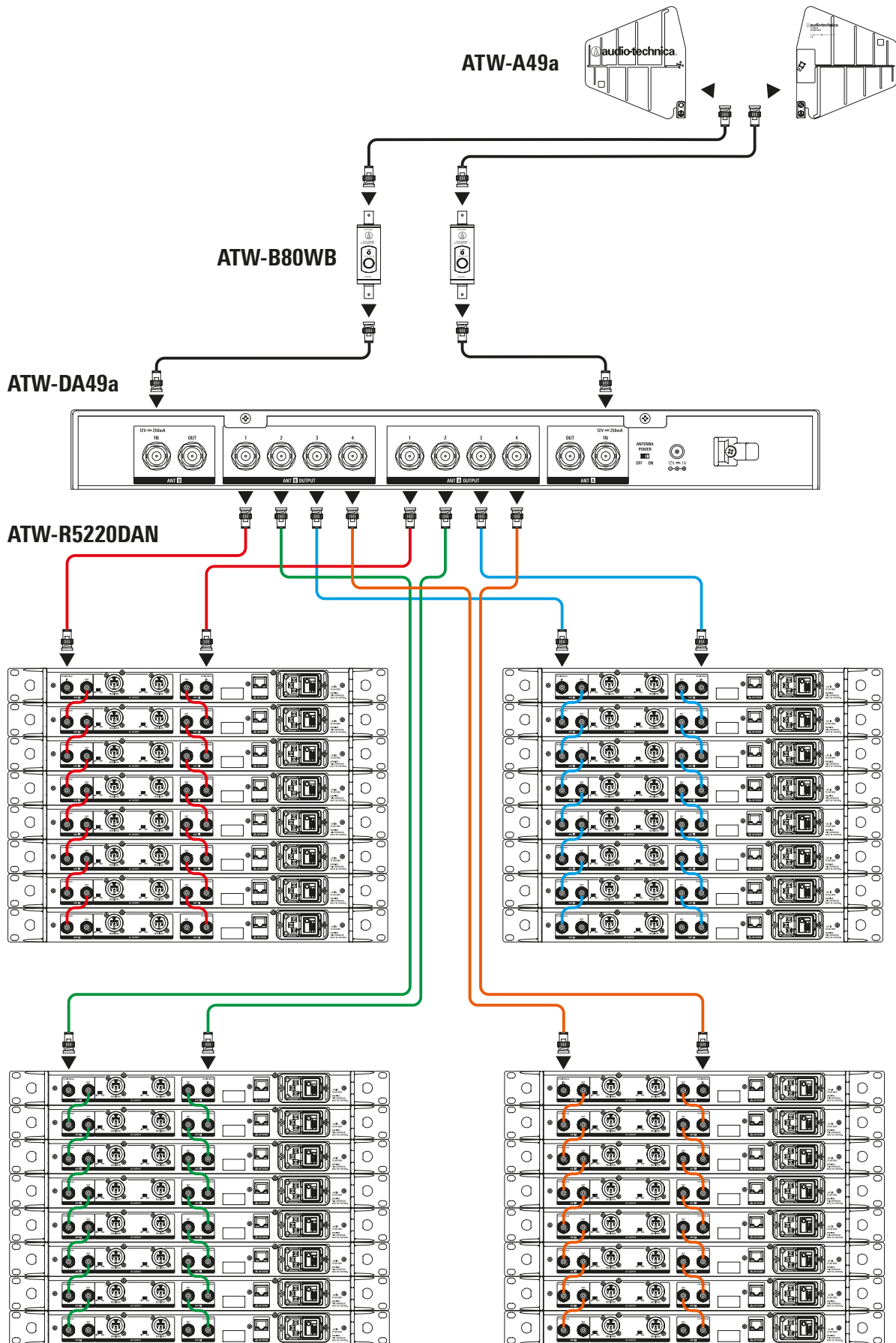

## Up to 8-Channels per Receiver

### Small to Medium Conference Room Use

Any combination of up to 8 handheld, body-pack, desk stand, or boundary transmitters may be used simultaneously with a single ESW-R4180DAN receiver. Simply connect a receiver via Cat 5e cable to a PoE network switch. To further simplify cable management, 8 bays of transmitter charging may be powered off of one AC adapter and connected via one Cat 5e cable for monitoring.



## Product table

Quantity	Code	Description	Notes
1	<b>ESW-R4180DAN</b>	8ch Receiver	
1-8	<b>ESW-T4101</b>	Body-Pack Transmitter	Any combination of transmitters
1-8	<b>ESW-T4102/C510</b>	Handheld Transmitter	Any combination of transmitters
1-8	<b>ESW-T4106</b>	Boundary Microphone Transmitter	Any combination of transmitters
1-8	<b>ESW-T4107</b>	Desk Stand Transmitter	Any combination of transmitters
1-8	<b>ES925</b>	Gooseneck Microphone	Use with ESW-T4107
1-4	<b>ESW-CHG4</b>	Two-Bay Charging Station	
1-2	<b>ESW-CHG5</b>	Four-Bay Charging Station	

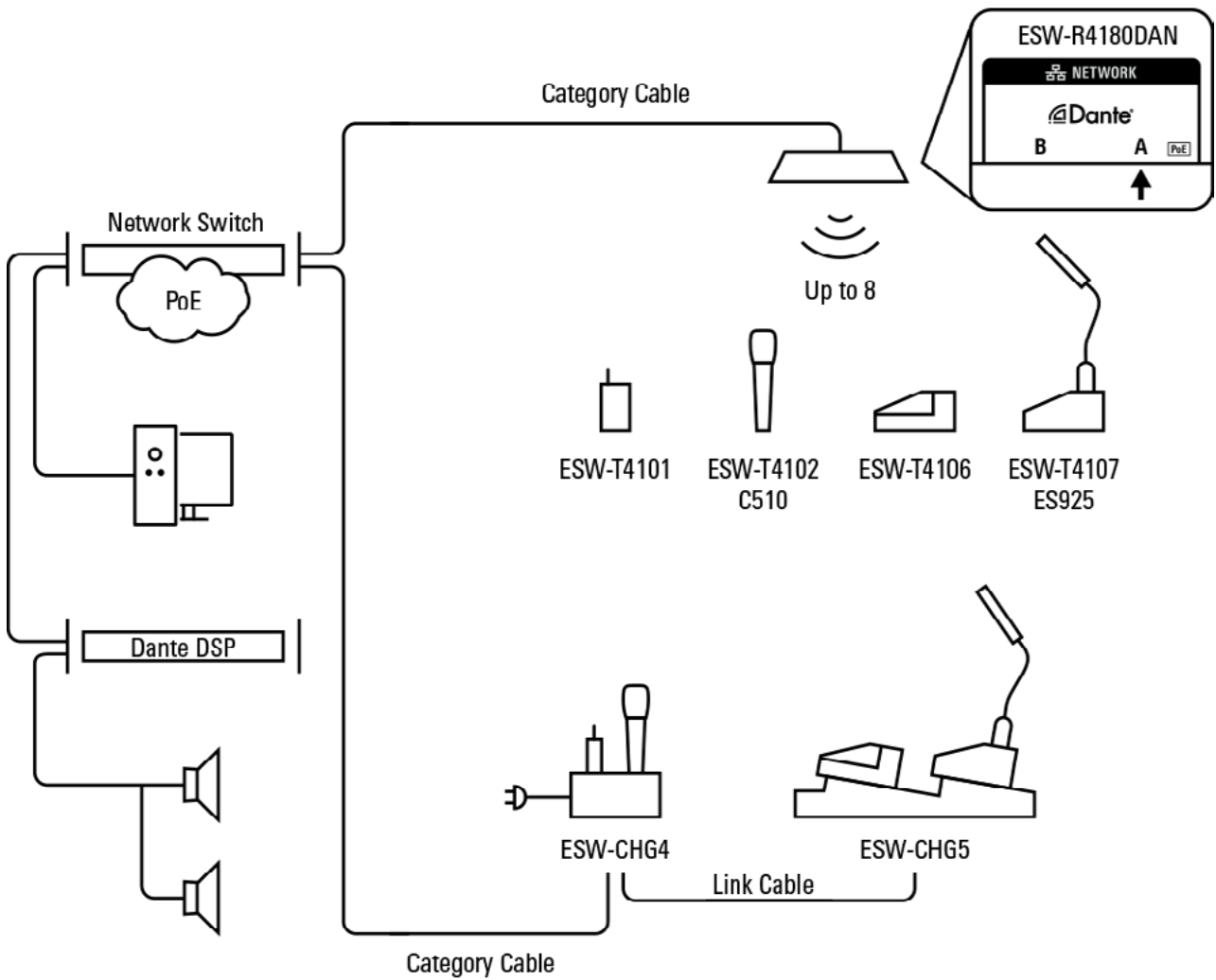

## Up to 192 Channels of ES Wireless Large Conference Room Use

Any combination of up to 8 handheld, body-pack, desk stand, or boundary transmitters may be used simultaneously with each ESW-R4180DAN receiver.

Up to 12 receivers can be used providing a maximum count of 192 simultaneous channels (when utilizing HD mode). Simply connect each receiver via Cat 5e cable to a PoE network switch. To further simplify cable management, 8 bays of transmitter charging may be powered off of one AC adapter and connected via one Cat 5e cable for monitoring.



### Product table

Quantity	Code	Description	Notes
1-8	<b>ESW-R4180DAN</b>	8ch Receiver	
1-64	<b>ESW-T4101</b>	Body-Pack Transmitter	Any combination of transmitters
1-64	<b>ESW-T4102/C510</b>	Handheld Transmitter	Any combination of transmitters
1-64	<b>ESW-T4106</b>	Boundary Microphone Transmitter	Any combination of transmitters
1-64	<b>ESW-T4107</b>	Desk Stand Transmitter	Any combination of transmitters
1-64	<b>ES925</b>	Gooseneck Microphone	Use with ESW-T4107
1-4	<b>ESW-CHG4</b>	Two-Bay Charging Station	
1-2	<b>ESW-CHG5</b>	Four-Bay Charging Station	

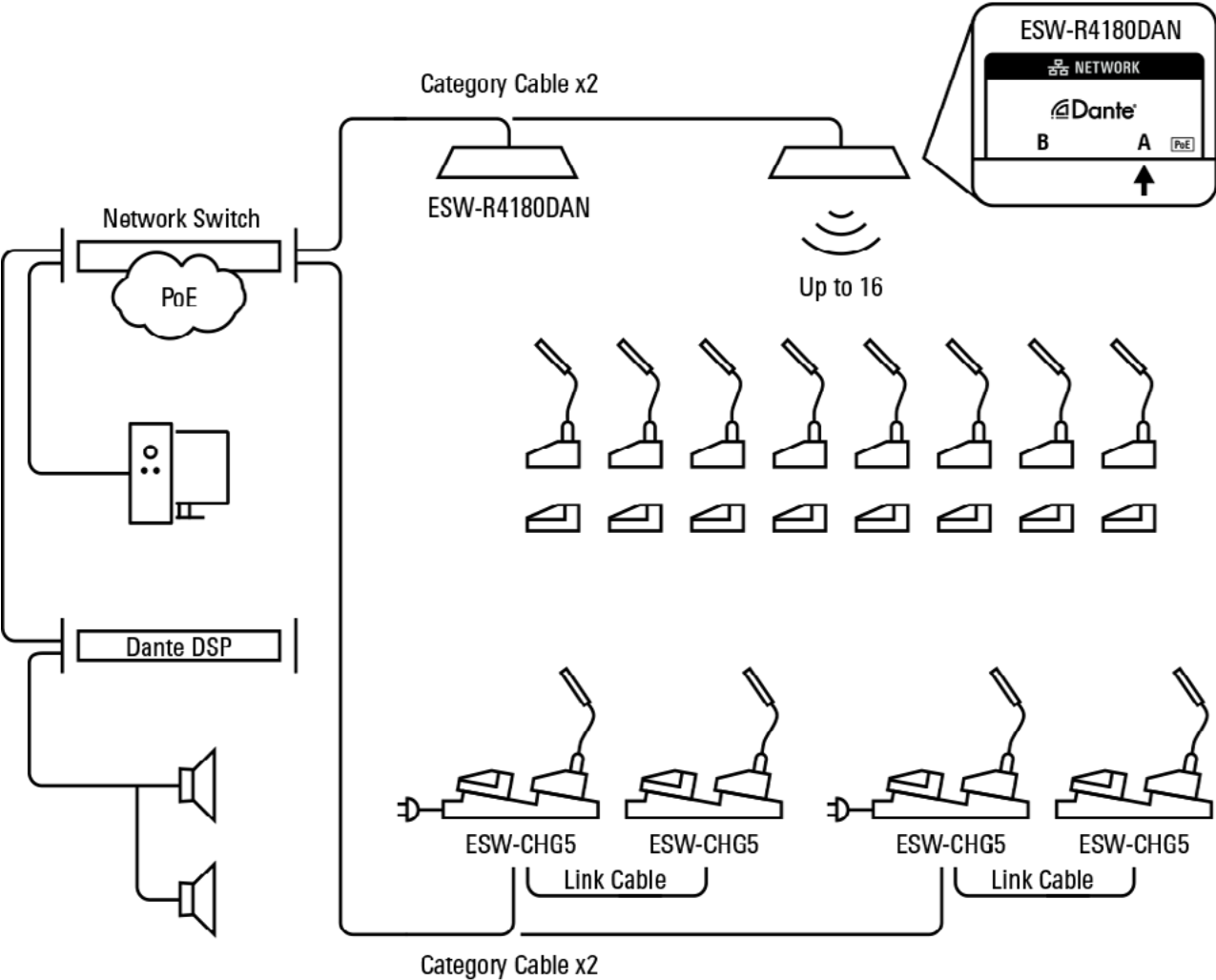

## System 20 PRO Multi-channel wireless system for install

This solution is aimed at fixed installations where the use of UHF TV bands is not preferred, such as in locations with a restricted RF environment or where the customer wishes to avoid licensing costs and the need for frequency coordination. Typical applications for this include educational facilities such as schools or universities, multi-function rooms, or conference centres.

This application is based around our System 20 PRO wireless system. System 10 does not use the UHF TV band frequency spectrum (470 - 865 MHz) associated with our other wireless products but operates on the 2.4GHz spectrum, most used for WLAN and Bluetooth® transmission. 2.4GHz offers many benefits, but you must also consider its limitations when using it for wireless audio.

The immediate advantage is that System 20 PRO is completely license free in almost all countries and requires no frequency planning by the installer or operator. However, due to the small wavelength of the 2.4GHz signal (around 12cm), the operating range is shorter than our other wireless systems which use the lower UHF range. This solution is not ideal for open-air scenarios, where long operating distance is required.

However, reduced operating range can also have benefits. For example, if multiple rooms located side-by-side all require a dedicated wireless system, you can reuse the same spectrum by using System 20 PRO in adjacent rooms – very little physical separation between rooms is required.

Another challenge with the 2.4GHz range is the parallel use of Wi-Fi alongside our wireless system. In this case, it is recommended to utilise 5.8GHz for Wi-Fi connectivity in place of 2.4GHz. If this is not possible, the placement of your wireless microphone receiver becomes very important. Here is why System 20 PRO offers the right solution.

2.4GHz antenna cables suffer from higher power losses over their cable run than UHF frequencies. At the same time, many installers do not wish to locate audio racks of receivers in the meeting room, but instead place them in a separate A/V room with the audio mixer and other equipment.

With System 20 PRO, the ATW-RU14 receiver unit can be removed and mounted remotely, connecting to the ATW-RC14 via standard ethernet cable. The ATW-RC14 can stay in the audio rack, whilst the ATW-RU14 can be mounted up to 100m away – on a wall, in the presenter podium, or hidden above the false ceiling in the room. The ATW-RU14 receiver unit is compact in size, and its included wall-mount housing can be painted in any colour to conceal it further.

Ensure to mount ATW-RU14 units as close as possible to the area where the wireless microphones will be used and aim to position any Wi-Fi access points at the opposite side of the room for maximum signal stability.

The compatible Audio-Technica wireless system for this solution is the System 20 PRO.



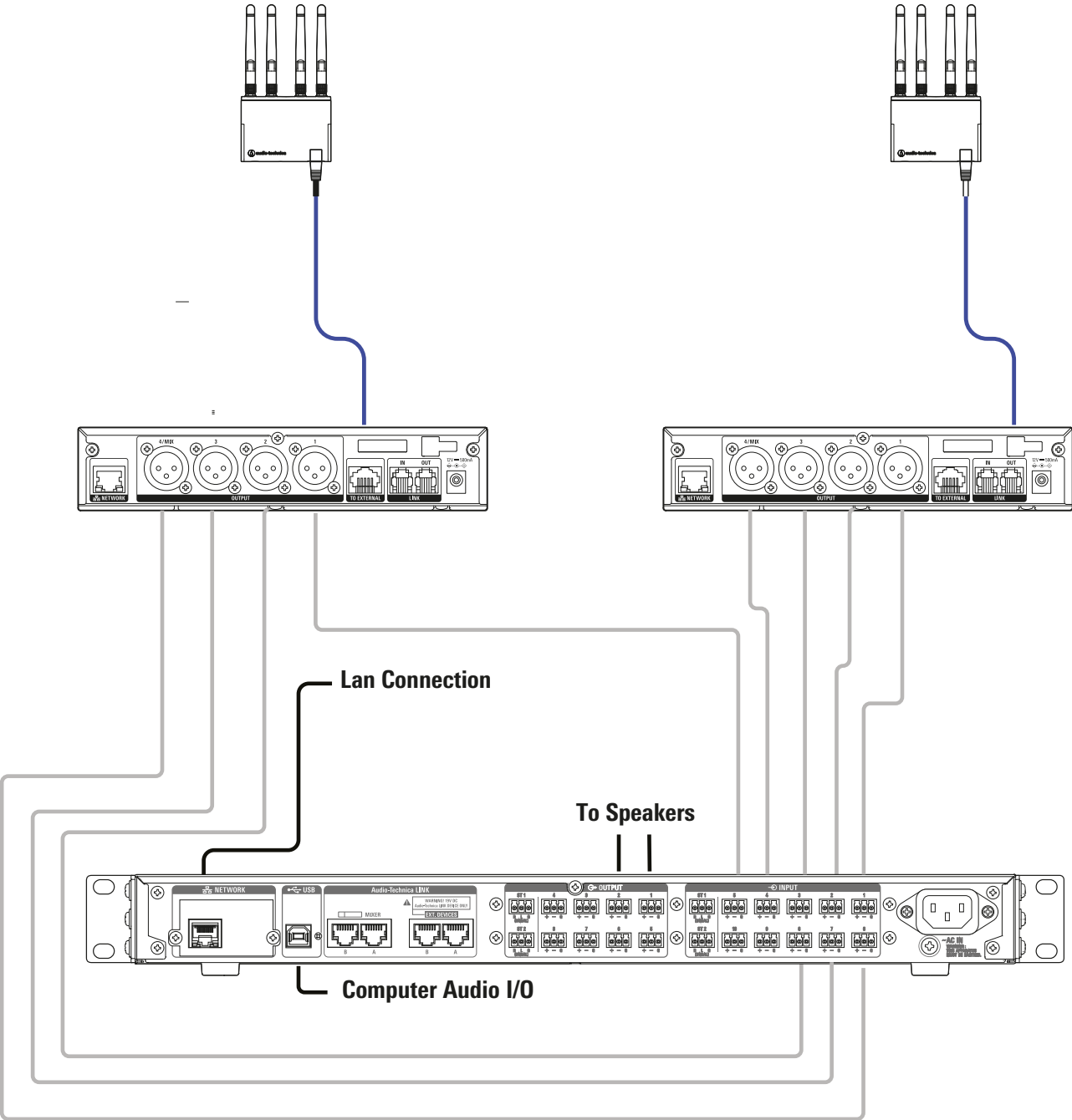

### Product table

Quantity	Code	Description	Alternative
2	ATW-R1440	Sys 20 PRO Quad Receiver	
8	ATW-T1406	Sys 20 PRO Boundary Microphone Transmitter	ATW-T1401, ATW-T1402, ATW-T1407
1	ATDM-1012	Digital Smart Mixer	





+	OK to use - licensefree, Може да се използва - Безплатен лиценз, U redu za korištenje - Bez licence, Bez omezení - Bez licence, Ok at bruge - Licens fri, Sobilik kasutada - litsensivaba, Käyttävissä - Lisenssivapaa, Usage autorisé - Licence libre, Zur Nutzung freigegeben - Lizenzfrei, Επιτρεπτή Χρήση - Χρήση Ανευ άδειας, Használható - Díjmentes, OK a úsáid - ceadúnas saor in aisce, OK utilizzo - Senza licenza, Var izmantot - Licence nav nepieciešama, Leidžiama naudoti - Nelicenzijuojamas, Huwa permess li jintuza - Mhemmx bzonn licenzja, Gebruik toegestaan - Vergunningsvrij, wolno używać - nie wymagana licencja, Ok para usar - Licença livre, Se poate folosi - Nu necesită licență, Bez obmedzenia - Bez licencie, Lahko se uporablja - Brez licence, Ok para usar - Licencia libre, OK att använda - Undantag från tillståndsplikt, lagi ađ nota - Má nota án leyfis, Kan benyttes - Lisensfri									
L	License needed, Платен лиценз, Licença potrebna, Nutná licence, Licens påkrævet, Litsents vajalik, Lisenssi tarvitaan, Licence nécessaire, Lizenz- und Anmeldepflichtig, Με Χρήση άδειας, Licenc köteles, Ceadúnas ag teastáil, Licença necessaria, Licence ir nepieciešama, Licenzijuojamas, Hemm bzonn licenzja, vergunningsplichtig, wymagana licencja, Licença necessária, Necesită licență, Nutná licencia, Licença potrebna, Licencia necesaria, Tillstånd krävs, Þarfnast leyfis fyrir notkun, Lisens nødvendig									
in	Indoor only, Само за вътрешно използване, Samo u zatvorenom prostoru, Pouze pro indoor, Kun indendørs, Ainult siseruumides, Vain sisäkäyttöön, Intérieur uniquement, Nur in geschlossenen Räumen, Χρήση MONO σε Εσωτερικούς Χώρους, Csak beltérben, Dhion ach, Solo uso al chiuso, Tikai iekštelpās, Naudojimui tik patalpoje, Gewwa biss, Alleen in gesloten ruimte, tylko w pomieszczeniach, Somente uso interior, Doar pentru interior, Iba pre indoor, Samo v zaprtem prostoru, Sólo en interiores, Endast inomhus, Aðeins innandyrá notkun, Kun innendørs									
-	Not allowed to use, Не се разрешава използването, Korištenje nije dopušteno, Zakázáno používat, Ikke tilladt at bruge, Ei ole lubatud kasutada, Käyttö ei sallittu, Ne pas utiliser, Nutzung verboten, Μη Επιτρεπτή Χρήση, Tilos használni, Ní cheadaítear a úsáid, Uso non permesso, Nedrīkst izmantot, Neleidžiama naudoti, Mhux permess li jintuza, Gebruik niet toegestaan, nie wolno używać, Não é permitido usar, Nu este permisă folosirea, Zakázané používať, Uporaba ni dovoljena, No se permite el uso, Inte tillåtet att användas, Má ekki nota, Ikke tillatt									
	P1	P1a	P1b	P12	P2	P2a	P2b	P2c	P2d	
	Power limit, Лимит на мощността, Granice snage, Max. výstupní výkon, Sendestyrke maksimalt, Võimsuse limiit, Lähetystehorajoitus, Puissance limitée à, Max. Sendeleistung, Επιτρεπτό Όριο ισχύος μέχρι, Teljesítmény korlát, Teorainn power, Limite di potenza, Jaudas robežvērtība, Galios apribojimas, Sahha limitata sa, Maximaal zendvermogen, limit mocy, Limite de potência, Limita puterii, Max. výstupný výkon, Jakostna omejitev, Potencia limitada a, MAX, Afl takmörkun, Maksimalt tillatt utstrålt effekt									
	10 mW ERP	10 mW ERP	10 mW EIRP	12 mW ERP	20 mW ERP	20 mW ERP	20 mW EIRP	20 mW ERP	20 mW EIRP	
		50 mW ERP	50 mW EIRP			50 mW ERP	50 mW EIRP	100 mW ERP	100 mW EIRP	
x1	NO	Vær vennlig å sjekke på <a href="http://www.finnsenderen.no/traadlos">http://www.finnsenderen.no/traadlos</a> hvilke frekvenser som kan benyttes i ditt område. Please check on <a href="http://www.finnsenderen.no/traadlos">http://www.finnsenderen.no/traadlos</a> which frequencies can be used in your area.								
x2	GR	Εξάφρεση για μεμονωμένη/ανεξάρτητη άδεια χρήσης, και για συσκευές ισχύος εκπομπής μέχρι 10 mW. Εξάφρεση για μεμονωμένη/ανεξάρτητη άδεια χρήσης, και για συσκευές ισχύος εκπομπής μεγαλύτερης από 10 mW. Exemption for individual licensing for devices with power of up to 10mW. Individual licensing required for devices with power over 10mW.								
x3	MT	Jekk joghgbok iccekkja r-regolamenti lokali dwar l-ahhar informazzjoni fuq l-uzu ta' "wireless microphones" Please check local regulation for the latest information about usage of wireless microphones								

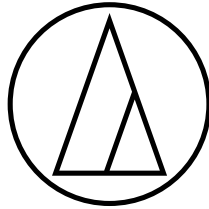

**audio-technica**

**Audio-Technica UK**

Audio-Technica Ltd.  
Technica House  
Unit 5, Millennium Way  
Leeds, LS11 5AL  
England

T: +44 (0)113 277 1441  
F: +44 (0)113 270 4836

E: [info@audio-technica.co.uk](mailto:info@audio-technica.co.uk)  
[audio-technica.com/en-gb/](https://audio-technica.com/en-gb/)

**Audio-Technica Germany**

Audio-Technica Deutschland GmbH  
Peter-Sander-Str. 43 C  
D-55252 Mainz-Kastel  
Germany

T: +49 (0) 6134 25734 0  
F: +49 (0) 6134 25734 50

E: [info@audio-technica.de](mailto:info@audio-technica.de)  
[audio-technica.com/de-de](https://audio-technica.com/de-de/)

**Audio-Technica France**

Audio-Technica SAS  
130, rue Victor Hugo  
92300 Levallois-Perret  
France

T: +33 (0) 1 43 72 82 82  
F: +33 (0) 1 43 72 60 70

E: [info@audio-technica.fr](mailto:info@audio-technica.fr)  
[audio-technica.com/fr-fr/](https://audio-technica.com/fr-fr/)

**Audio-Technica Spain**

Audio-Technica Iberia SAU  
**Oficina Barcelona:** Montserrat Roig 13  
08908 L'Hospitalet de Llobregat  
Barcelona, Spain  
T: +34 935 222 450

**Oficina Madrid:** Fresadores 35  
28939 Arroyomolinos, Madrid, Spain  
T: +34 913 619 081

E: [info@audio-technica.es](mailto:info@audio-technica.es)  
[audio-technica.com/es-es/](https://audio-technica.com/es-es/)

**Audio-Technica Central Europe**

Audio-Technica Central Europe Ltd.  
H-1107 Budapest  
Fogadó u. 3.  
Hungary

T: +36 1 433 34 08  
F: +36 1 431 90 06

E: [info-ce@audio-technica.eu](mailto:info-ce@audio-technica.eu)  
[audio-technica.com/world\\_map/](https://audio-technica.com/world_map/)

**Audio-Technica Benelux**

incorporating lemke Roos Audio  
Audio-Technica Benelux B.V.  
Kuiperbergweg 20  
1101 AG Amsterdam  
The Netherlands

T: + 31 20 6972121

E: [info@audio-technica.nl](mailto:info@audio-technica.nl)  
[audio-technica.com/nl-nl/](https://audio-technica.com/nl-nl/)

©2024 Audio-Technica Ltd

E&OE\*: Published specifications may be subject to change without notice.  
(\*Errors and Omissions Excepted)